

We Bring Air to Life
*Technical Catalogue > Controls, Switches and Drivers
for Demand Control of Fans*



AIRTREND Limited
Predstavništvo u Beogradu
Kumanovska 14, 11000 Beograd
Tel: 011 3836886, 3085740
Faks: 011 3444113
e-mail: gobrid@eunet.rs
web: www.airtrend.rs

FläktWoods

Contents

Controls, Switches and Drivers for Demand Control of Fans

Quick Selection Table - Drives.....	2
Quick Selection Table – Sensors, Switches & Controllers.....	3
Electronic Speed Controllers & Drives – Single Phase	
EEID – Electronic Single Phase Independent Drive.....	4
EEDS – Electronic Single Phase Demand Switched Drive.....	6
EEDP – Electronic Single Phase Demand Proportional Drive.....	8
ME – Electronic Single Phase Classic Drive.....	10
Transformer Speed Controllers & Drives – Single Phase	
TEID – Transformer Single Phase Independent Drive.....	12
TEDS – Transformer Single Phase Demand Switched Drive.....	14
TEDSD – Transformer Single Phase Demand Switched Dual Speed Drive.....	16
TEDP – Transformer Single Phase Demand Proportional Drive.....	18
Transformer Speed Controllers & Drives – Three Phase	
TDID – Transformer Three Phase Independent Drive.....	20
TDDS – Transformer Three Phase Demand Switched Drive.....	22
TDDSD – Transformer Three Phase Demand Switched Dual Speed Drive.....	24
TDDP – Transformer Three Phase Demand Proportional Drive.....	26
Inverter Speed Control & Drives	
IDDXB20 – Inverter Three Phase IP20 Demand Independent, Switched and Proportional Drive – For Tube/Box Fans.....	28
IDDXF20 – HVAC Inverter Three Phase IP20 Demand Independent, Switched and Proportional Drive – For Axial & Centrifugal Fans.....	30
IDDXF54 – HVAC Inverter Three Phase IP54 Demand Independent, Switched and Proportional Drive – For Axial & Centrifugal Fans.....	32
IDDXF66 – HVAC Inverter Three Phase IP66 Demand Independent, Switched and Proportional Drive – For Axial & Centrifugal Fans.....	34
IEDXB20 – Inverter Single to Three Phase IP20 Demand Independent, Switched and Proportional Drive – For Tube/Box Fans.....	36
Isolation Switches	
SISO – Safety Isolators/Switch-Disconnectors.....	38
Sensors & Switches	
SDXT – Room Temperature Sensor/Switch Controller for Demand Proportional & Switched Drives.....	40
SDXC – Room CO ² Sensor/Switch Controller for Demand Proportional & Switched Drives.....	42
SDSI – Room Passive Infrared Switch for Demand Switched Drives (PIR).....	45
SDSP54 – Pressure Switch for Demand Switched Drives.....	46
SDXP54 – Pressure Sensor Controller for Demand Proportional Drives.....	48
SDPT54 – Room Temperature Sensor Controller for Demand Proportional Drives.....	51
SDPUSB – USB to Modbus RTU RS485 Connector.....	54
Potentiometers & Power Supply	
SDPV-10 – Room Potentiometer for Demand Proportional Drives.....	56
SDPV-230 – Room Potentiometer for Demand Proportional Drives.....	58
SDXV – Power Supply for Sensors & Switches 230VAC to 24VDC.....	60

Quick Selection Table - Drives

Typical Use		Boxed & Duct Fans: Espada, Ropera, Sabina, Estoc, Estoc-Targe, Falcata, Katana & Roof										Axial & Centrifugal																																																																																																												
Method	Electronic	Transformer					Inverter																																																																																																																	
Phase	1	3					3-3					3-3																																																																																																												
Voltage	230V 50Hz	230V 50/60Hz					400V 50/60Hz					400V 50/60Hz																																																																																																												
IP	54	54					20					20 54 66																																																																																																												
Energy Efficiency																																																																																																																								
Control Method	Independent	Switched	Proportional	Amps (FLC Continuous)		Independent	Switched	Proportional	Amps (FLC Continuous)		Switched and Proportional	Switched and Proportional	Switched and Proportional	Switched and Proportional																																																																																																										
Model	EED	EEDS	EEDP	Amps (FLC Continuous)		TEID	TEDS	TESD	TEDP	Amps (FLC Continuous)		TDD	TDDSD	TDDP	IEDX820	IDDX820	IDDXF20	IDDXF54	IDDXF66																																																																																																					
Image																																																																																																																								
DHP	1	2	3	4	6	10	1.0	1.5	2.2	3.5	5.0	7.5	13.0	2.5	4.0	8.0	11.0	2.5	4.0	8.0	11.0	2.2	3.7	5.3	7.2	9.0	12.0	15.5	23.0	37.0	42.5	61	73	90	106	147	177																																																																																			
Select Part Number	EA900100	EA900101	EA900102	EA900103	EA900104	EA900105	EA900000	EA900001	EA900002	EA900003	EA900004	EA900005	EA900006	EA900007	EA900008	EA900009	EA900010	EA900011	EA900012	EA900013	EA900014	EA900015	EA900016	EA900017	EA900018	EA900019	EA900020	EA900021	EA900022	EA900023	EA900024	EA900025	EA900026	EA900027	EA900028	EA900029	EA900030	EA900031	EA900032	EA900033	EA900034	EA900035	EA900036	EA900037	EA900038	EA900039	EA900040	EA901050	EA901042	EA901043	EA901044	EA901045	EA901046	EA901047	EA901048	EA901049	EA901008	EA901009	EA901010	EA901011	EA901012	EA901013	EA901014	EA901015	EA901016	EA901017	EA901018	EA901019	EA901020	EA901021	EA901022	EA901023	EA901024	EA901025	EA901026	EA901027	EA901028	EA901029	EA901030	EA901031	EA901032	EA901033	EA901034	EA901035	EA901036	EA901037	EA901038	EA901039	EA901040	EA901041	EA901042	EA901043	EA901044	EA901045	EA901046	EA901047	EA901048	EA901049	EA901050	EA901051	EA901052	EA901053	EA901054	EA901055	EA901056	EA901057	EA901058	EA901059	EA901060	EA901061	EA901062	EA901063	EA901064	EA901065	EA901066	EA901067	EA901068	EA901069	EA901070	EA901071

EEID – Electronic Single Phase Independent Drive



Features

- Independent control of fan speed. Infinitely variable from max to min with off position
- Supply 230 VAC, 50/60 Hz, 1 Phase
- IP54 Surface & IP44 Inset ingress protection rating
- Two & Three wire control
- Clear indication light
- Commissioning adjustable minimum speed pre-set to 20% via internal potentiometer
- Fuse 5*20mm, spare included
- RAL9010 white ivory enclosure and face. Internal polyamide.
- Max ambient temperature: 50°C

Description

The compact units of the EEID series control the speed of single phase voltage controllable motors (230 VAC, 50/60 Hz) by varying the supplied voltage via optotriac phase angle control.

An LED indicates operational status with the hand controlled dial providing infinitely variable and off positioning. Suitable for inset or surface mounting with the splash-resistant housing provided.

A safety isolator/switch disconnecter should be installed on the mains side of all motor drives;

Range

For selection of the drive current rating choose a controller model with a current rating equal to or above the fan full load current (FLC). If the motor is fitted with thermostat (Tk) overheat protection we recommend the EEDS controller range to enable this function.

MODEL	EEID1A	EEID2A	EEID4A
PART	EA900100	EA900101	EA900102
CURRENT RATING (A)	0.1 - 1.0	0.2 - 2	0.4 - 4
FUSE (A) 5*20MM	F1.25A H	F2.5A H	F5.0A H
INGRESS PROTECTION	IP44/54	IP44/54	IP54*

*Surface mount only

Wiring Diagram

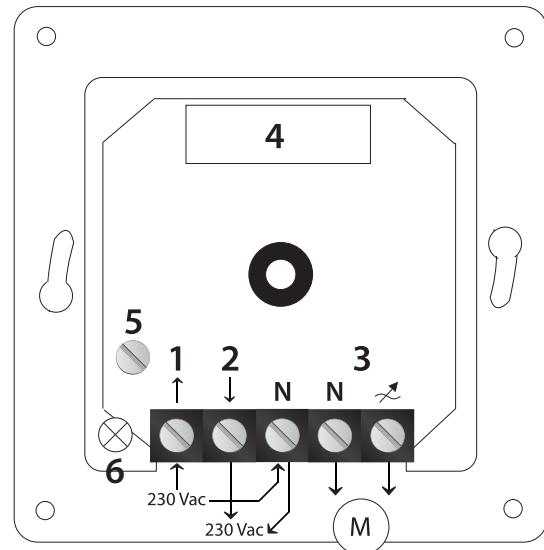

- 1 - Power supply 230 VAC, 50 Hz
- 2 - 230 VAC non-regulated output for connecting valve, dampers or three wire motor connection
- N - Neutral
- 3 - Regulated output to motor
- 4 - Fuse holder with spare
- 5 - Minimum speed adjustment trimmer (pre-set to 20%)
- 6 - Control light

Dimensions & Weights

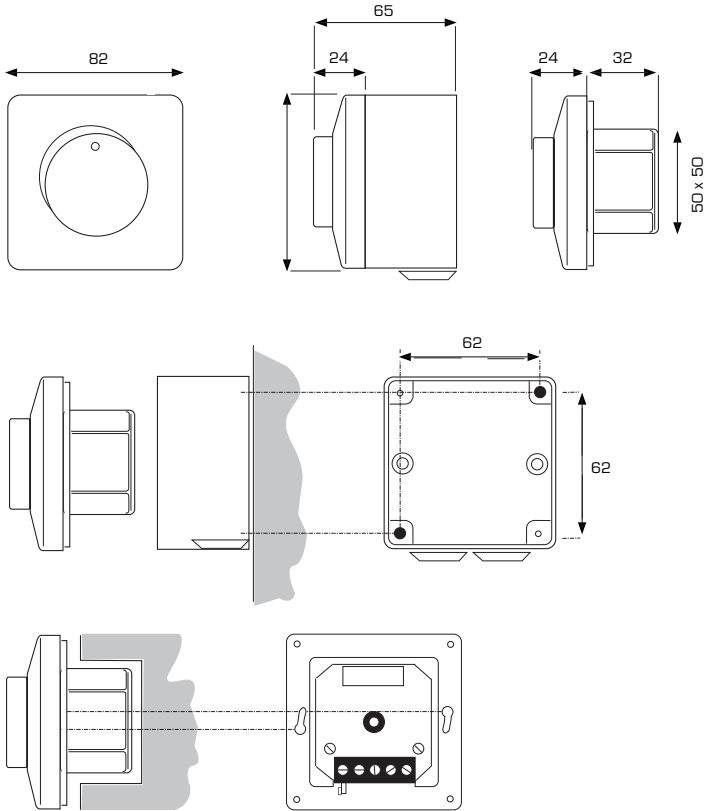

MODEL	EEID1A	EEID2A	EEID4A
PART	EA900100	EA900101	EA900102
NET WEIGHT (G)	210	215	300
GROSS WEIGHT (G)	235	240	325

Mounting Instructions

EEID electronic fan speed controller for single phase voltage controllable motors.

Inset mounting (IP 44)

Break (Isolate) mains voltage. Connect according to diagram. Mount inner case to the wall with connections pointing down. Turn on mains voltage and controller. Adjust min. speed with insulated screwdriver and turn off controller. Mount cover with nut to the wall. Push knob in place at off position.

Surface mounting (IP 54)

Break (Isolate) mains voltage. Mount surface mounting case to the wall together with included grommets. Connect according to diagram. Turn on mains voltage and controller. Adjust min. speed with insulated screwdriver and turn off controller. Mount cover with nut to surface mounting case. Push knob in place at off position.

Adjustment

Trimmer (MIN) - Adjust with insulated screwdriver so that the motor does not stop due to variations of mains voltage and that it restarts after power failure.

Wiring (see previous page)

A safety isolator/switch disconnecter should be installed on the mains side of all motor drives; refer to SISO.

We recommend three wire control for increased speed stability and low speed starting.

All dimensions shown in mm

Change of fuse

Break (Isolate) mains voltage. Undo knob by first turning the knob to the right beyond end stop and then pull. Remove the nut. Remove fuse holder with a screwdriver. Change fuse. Put the details back in place. Use only recommended fuses (Approved, fast, with high breaking capacity).

Motor protection

If motors are fitted with thermostat (Tk) overheat protection it is recommended to use the EEDS range to utilise this feature.

Warranty

Two years from delivery date against defects in manufacturing. Any modifications or alterations to the product relieve the manufacturer of all responsibility. The manufacturer bears no responsibility for any misprints or mistakes in this data, and modifications or improvements to the product can be made at any time after date of publication.

Maintenance

In normal conditions the controllers are maintenance-free. If soiled clean with dry or damp cloth. In case of heavy pollution clean with a non-aggressive product. In these circumstances the controller should be disconnected from the mains. Pay attention that no fluids enter the controller. Only reconnect the controller to the mains when it is completely dry.



General danger

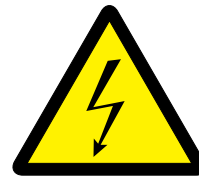

Electrical hazard

All works may only be carried out by skilled personnel following the local regulations and AFTER the controller is completely separated from the mains. Replace fuse only with same type and rating.

EEDS – Electronic Single Phase Demand Switched Drive



Features

- Switched control of fan speed. Infinitely variable from max to min with on/off switch
- Supply: 230 VAC, 50/60 Hz, 1 Phase
- IP 54 ingress protection
- In built motor overheat protection via motor thermostats (Tk)
- BMS enable/disable (Fault via Tk)
- Two & Three wire control
- Switched input / startup to front dial setting/ kick start: 6-7 sec. full speed
- Minimum and maximum speed setting trimmers
- Plastic enclosure (R-ABS, UL94-V0, grey RAL 7035), IP 54
- Max ambient temperature: 50°C

Description

The electronic speed controllers of the EEDS series control the speed of single phase voltage controllable motors (230 VAC, 50/60 Hz) by varying the supplied voltage.

The controller has connections for motors equipped with thermostat (Tk) overheat protection (NC-contact). When overheating is detected power to the motor is stopped. The red indicator light and alarm output will signal this error condition (reset: main switch to off position and back).

The working principle of this product series is based on zero crossing detection. An optotriac combined with a microprocessor ensures flawless and accurate control.

OC (open contact - normal mode) and CC (closed contact - normal mode) inputs are provided for remote starting and stopping via thermostats, PIR and/or frost protection, etc.

There is a potentiometer and a separate on/off switch with built-in illumination. The terminal board has a supplementary connection to branch off non-controlled 230 V.

A safety isolator/switch disconnecter should be installed on the mains side of all motor drives; refer to SISO.

Range

For selection of the drive current rating choose a controller model with a current rating equal to or above the fan full load current (FLC). If the motor is fitted with thermostat (Tk) overheat protection we recommend the EEDS controller range to enable this function.

MODEL	EEDS3A	EEDS6A	EEDS10A
PART	EA900103	EA900104	EA900105
CURRENT RATING (A)	0.1 – 3.0	0.5 – 6.0	0.5 – 10.0
FUSE (A) 5*20MM	F5 A-H	F8 A-H	F14 A-H (6X32)
INGRESS PROTECTION	IP54	IP54	IP54

Wiring Diagram

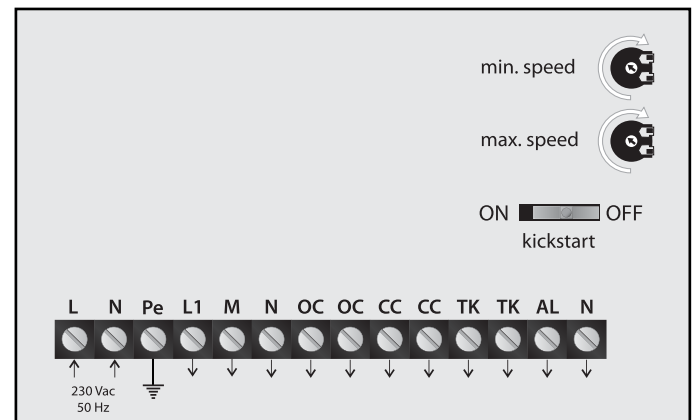

L-N - Power supply 230 VAC, 50 Hz, 1 Phase

Pe - Power earth

L1-N - 230 VAC non-controlled outputs

OC - Normal open contact, thermostat, timer, frost protection, PIR, BMS remote on/off

CC - Normal closed contact (inverse logical)

N-AL - Alarm output in case of motor fault 230 VAC, 0,6 A (150 W)

TK – Connection for motor thermostat over heat protection. Can be used for BMS fault.

M-N - Motor connection

Min. speed - from 70 to 150 V – Pre-set 20%

Max. speed - from 170 to 230 V – Pre-set 100%

Dimensions & Weights

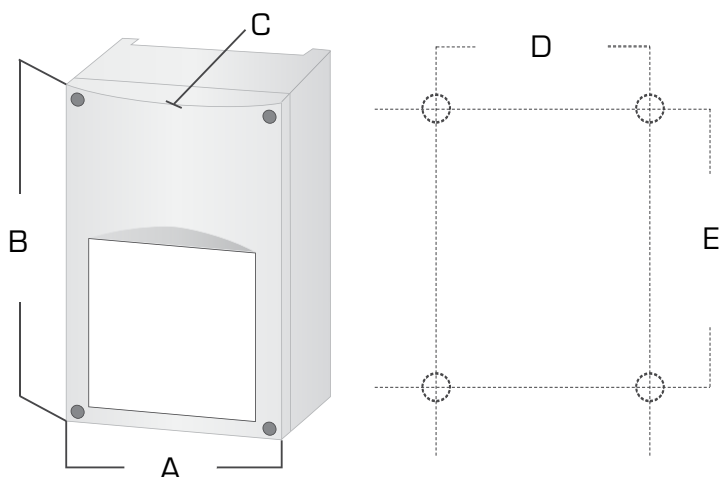

MODEL	A	B	C	D	E	Net g	Gross g
EEDS3A	83	160	66	71	108	420	440
EEDS6A	113	178	92	102	140	675	765
EEDS10A	113	178	92	102	140	650	740

Maintenance

In normal conditions the controllers are maintenance-free. If soiled clean with dry or damp cloth. In case of heavy pollution clean with a non-aggressive product. In ALL circumstances the controller should be disconnected from the mains. Pay attention that no fluids enter the controller. Only reconnect the controller to the mains when it is completely dry.

Motor protection

For use with motors fitted with thermostat (Tk) (NC contact) overheat protection.



General danger

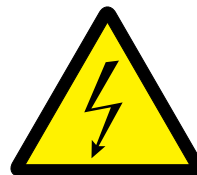

Electrical hazard

All works may only be carried out by skilled personnel following the local regulations and AFTER the controller is completely separated from the mains. Replace fuse only with same type and rating.

Mounting Instructions

Speed controller for voltage controllable single phase motors

Mounting

Break (Isolate) mains voltage. The controllers are to be mounted on a smooth surface. Connect voltage supply, motor(s) and earth as shown in the wiring diagram with cables of the proper diameter.

1. Break (Isolate) mains voltage & be sure that the controller is in OFF position.
2. Take off the box cover by loosening the four screws. Note that the potentiometer is connected to the PCB with two wires.
3. Connect mains, motor(s) and earth cables of the proper diameter to the terminals according to the wiring diagram.
4. Start the controller and with insulated screwdriver adjust the minimum speed: with the potentiometer at minimum, adjust the trimmer so that the motor continues running or restarts smoothly in case of power faults. The minimum speed is factory pre-set at 20% speed.
5. Close the box and verify the installation.
6. When reconnecting mains voltage if the green LED is flashing the connector for the external trimmer is unplugged.

Wiring (see previous page)

If TK-TK is not operational: [Link TK-TK](#)

A safety isolator/switch disconnecter should be installed on the mains side of the drive; refer to SISO.

We recommend three wire control for increased speed stability and low speed starting.

Transport and stock keeping

Avoid shocks. Store in original packing. Avoid extreme conditions.

Warranty

Two years from delivery date against defects in manufacturing. Any modifications or alterations to the product relieve the manufacturer of all responsibility. The manufacturer bears no responsibility for any misprints or mistakes in this data, and modifications or improvements to the product can be made at any time after date of publication.

EEDP – Electronic Single Phase Demand Proportional Drive



Features

- Proportional control of fan speed via 0-10VDC control signal with on/off switch
- Supply: 230 VAC, 50/60 Hz, 1 Phase
- IP54 ingress protection
- In built motor overheat protection via motor thermostat (Tk) . Can be used for BMS fault.
- Two & Three wire control
- BMS enable/disable (Fault via Tk)
- Control signal input: 0-10 VDC Supply: 12 VDC e.g. CO₂ pressure and temperature sensor
- Minimum and maximum speed setting trimmers
- Plastic enclosure (R-ABS, UL94-V0, grey RAL 7035), IP 54
- Max ambient temperature: 50°C

Description

The EEDP automatically controls the speed of single phase (230 VAC, 50/60 Hz) voltage controllable electric motor with a 0-10 VDC or 0-20 mA control signal. It is possible to invert the control signal to 10-0 VDC, 20-0 mA.

An illuminated external power switch is provided.

A supplementary terminal block is provided to branch off 230 VAC non-controlled for 3-wire motor connection or damper operation.

The working principle of this product series is based on zero crossing detection. An optotriac combined with a microprocessor ensures flawless and accurate control.

A kick star feature is selectable internally to start the motor for 10 sec at maximum speed.

The EEDP controllers have inbuilt connections for thermostat (Tk) motor protection (NC-contact). When the motor thermostats open, because of motor overheating, the circuit is broken and the controller stops power to the motor. After eliminating the cause of overheating the fan can be restarted by turning off the controller for a few moments.

A safety isolator/switch disconnecter should be installed on the mains side of all motor drives; refer to SISO.

Range

For selection of the correctly current rated drive select the model with a current rating equal to or above the fan full load current (FLC).

MODEL	EEDP3A	EEDP6A	EEDP10A
Part	EA900106	EA900107	EA900108
Current rating (A)	0.1 – 3.0	0.5 – 6.0	0.5 – 10.0
Fuse (A) 5*20mm	F5 A-H	F10 A-H	F16 A-H (6x32)
Ingress Protection	IP54	IP54	IP54

Wiring Diagram

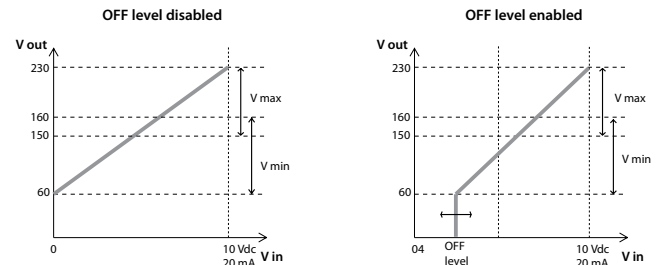

Calculation formula

$$V_{out} = ((V_{in}/10) * (V_{max} - V_{min})) + V_{min}$$

$$V_{out} = ((V_{in} - \text{OFF-level}) / (10 - \text{OFF-level})) * (V_{max} - V_{min}) + V_{min}$$

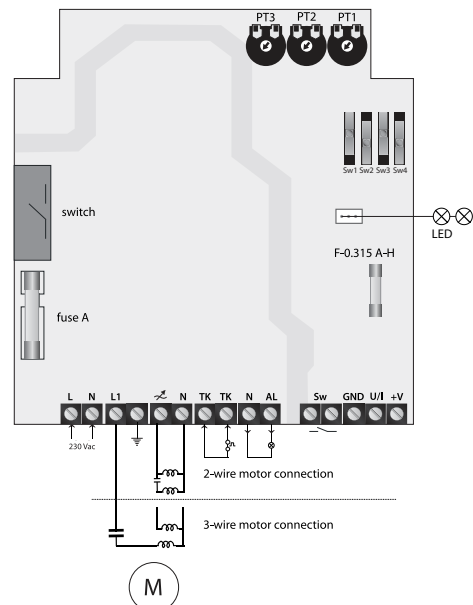

L - Mains supply 230 VAC, 50 Hz
 N - Neutral
 L1 - 230 VAC unregulated output (Imax 2 A)
 Earth - Terminal (only for 3, 6 & 10 A)
 M - Regulated output to motor
 TK - Connections for motor thermostat (Tk) overheat protection. Can be used for BMS fault.
 N AL - Alarm output 230 VAC, 1 A
 Sw - Switch BMS enable/disable (Fault via Tk)
 GND - Control Ground
 UI - Control signal 0-10 VDC (input impedance 90 kOhm)
 I - 0-20 mA (input impedance 250 Ohm)
 +V - Low voltage power supply: 12 VDC, 1 mA for external potentiometer
 Sw1 - Switch down = 0-10 V, up = 10-0 V
 Sw2 - Switch down = disable off-level, up = enable off-level
 Sw3 - Switch down = disable kick-start, up = enable kick-start
 Sw4 - Switch down = 0-20 mA, up = 0-10 V (select current/voltage)
 PT1 - Max. speed adjustment trimmer, range: 165-230 V
 PT2 - Min. speed adjustment trimmer, range: 60-160 V
 PT3 - Off-level adjustment trimmer: 0-4 V or 10-6 V (depending on Sw1)
 LED green: Normal operation. blinking: standby (input signal < off level).
 red: motor overheated (reset device by turning off and on again)

Motor protection

Connections provided for motors with thermostat (Tk) overheat protection (NC contacts).

Warranty

Two years from delivery date against defects in manufacturing. Any modifications or alterations to the product relieve the manufacturer of all responsibility. The manufacturer bears no responsibility for any misprints or mistakes in this data, and modifications or improvements to the product can be made at any time after date of publication.

Maintenance

In normal conditions the controllers are maintenance-free. If soiled clean with dry or damp cloth. In case of heavy pollution clean with a non-aggressive product. In these circumstances the controller should be disconnected from the mains. Pay attention that no fluids enter the controller. Only reconnect the controller to the mains when it is completely dry.



General danger

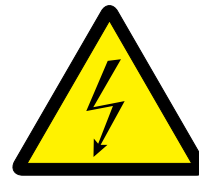

Electrical hazard

All works may only be carried out by skilled personnel following the local regulations and AFTER the controller is completely separated from the mains. Replace fuse only with same type and rating.

Dimensions & Weights

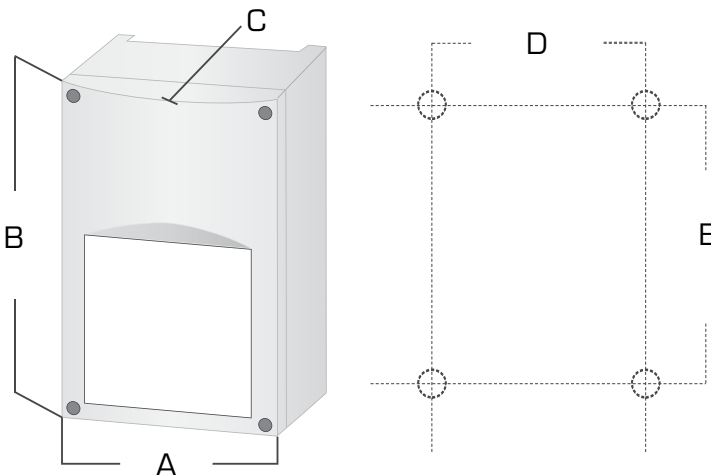

MODEL	A	B	C	D	E	Net g	Gross g
EEDP3A	113	178	92	102	140	700	815
EEDP6A	113	178	92	102	140	860	975
EEDP10A	113	178	92	102	140	860	975

Mounting Instructions

Speed controller for single phase voltage controllable motors.

Mounting

Break (Isolate) mains voltage. The controllers are to be mounted on a smooth surface. Connect voltage supply, motor(s) and earth as shown in the scheme with cables of the proper diameter.

Wiring (see diagram on previous page)

If TK-TK is not operational: Link TK-TK

A safety isolator/switch disconnecter should be installed on the mains side of the drive; refer to SISO.

We recommend three wire control for increased speed stability and low speed starting.

Transport and stock keeping

Avoid shocks. Stock in original packing. Avoid extreme conditions.

ME – Electronic Single Phase Classic Drive



Features

- Classic control of fan speed. Infinitely variable with illuminated on/off switch
- Supply: 230 VAC, 50/60 Hz, 1 Phase
- IP44 ingress protection
- Three wire control
- Infinitely variable voltage controller
- Max ambient temperature: 50°C

Description

The Classic ME series of drives provide speed control of single phase, 230 VAC, 50/60 Hz voltage controllable electric motors.

Available in 1, 3, 6 and 12 Amp units they have an illuminated on/off switch and infinitely variable control to minimum and maximum speeds.

A safety isolator/switch disconnecter should be installed on the mains side of all motor drives; refer to SISO.

Range

For selection of the correctly current rated drive select the model with a current rating equal to or above the fan full load current (FLC).

Model	ME1.1	ME1.3	ME1.6	ME1.12
Part	410289	410290	410291	414855
Current rating (A)	1	3	6	12
Ingress Protection	IP44	IP44	IP44	IP44

Wiring Diagram

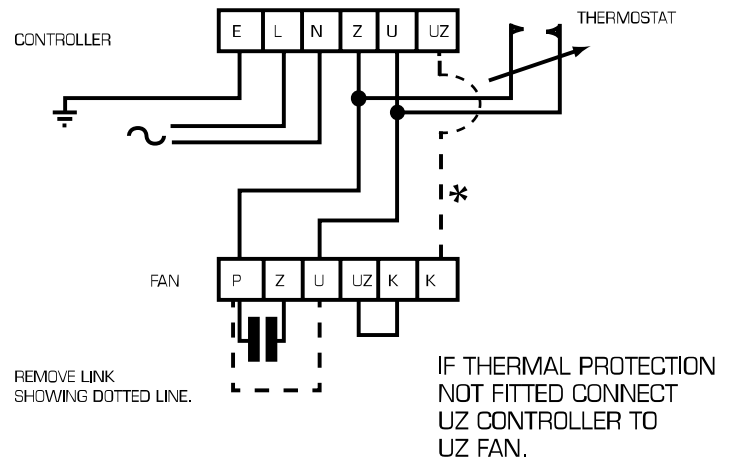

CD2249

* Add link between terminal UZ and K if three wire control is required.

Dimensions & Weights

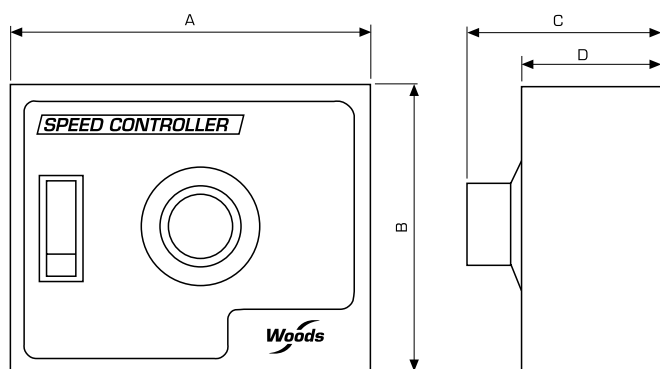

Model	A	B	C	D	Net g	Gross g
ME1.1	104	83	40	15	375	425
ME1.3	148	87	47	15	400	450
ME1.6	148	87	47	15	425	475
ME1.12	210	180	65	16	500	550

Mounting Instructions

Speed controller for single phase voltage controllable motors.

Mounting

Break (Isolate) mains voltage. The controllers are to be mounted on a smooth surface. Connect voltage supply, motor(s) and earth as shown in the scheme with cables of the proper diameter.

Wiring (see diagram on previous page)

A safety isolator/switch disconnecter should be installed on the mains side of the drive; refer to SISO.

We recommend three wire control for increased speed stability and low speed starting.

Motor protection

If motors are fitted with thermostat (Tk) overheat protection it is recommended to use the EEDS range to utilise this feature.

Transport and stock keeping

Avoid shocks. Stock in original packing. Avoid extreme conditions.

Warranty

Two years from delivery date against defects in manufacturing. Any modifications or alterations to the product relieve the manufacturer of all responsibility. The manufacturer bears no responsibility for any misprints or mistakes in this data, and modifications or improvements to the product can be made at any time after date of publication.

Maintenance

In normal conditions the controllers are maintenance-free. If soiled clean with dry or damp cloth. In case of heavy pollution clean with a non-aggressive product. In these circumstances the controller should be disconnected from the mains. Pay attention that no fluids enter the controller. Only reconnect the controller to the mains when it is completely dry.



General danger



Electrical hazard

All works may only be carried out by skilled personnel following the local regulations and AFTER the controller is completely separated from the mains. Replace fuse only with same type and rating.

Transformer Speed Controllers & Drives - Single Phase

TEID - Transformer Single Phase Independent Drive



Features

- Independent transformer 5 step speed control for fans with off position
- Supply: 230 VAC, 50/60 Hz, 1 Phase
- IP54 ingress protection
- Switch: 5 positions with off-position
- Indicator light
- Current fuse
- 230 VAC unregulated output
- Ready mounted cable glands
- Enclosure: plastic (R-ABS, UL94-V0, grey RAL 7035) or sheet steel (RAL 7035)
- Max ambient temperature: 50 °C

Description

The TEID transformer speed controllers are based on the principle of voltage control with autotransformers. They are applicable to single phase voltage controllable motors (230 V, 50/60 Hz) to control the rotational speed of fans in five steps.

A safety isolator/switch disconnecter should be installed on the mains side of all motor drives; refer to SISO.

Range

For selection of the correctly current rated drive select the model with a current rating equal to or above the fan full load current (FLC).

Model	TEID1A	TEID1.5A	TEID2.2A	TEID3.5A	TEID5A	TEID7.5A	TEID13A
Part	EA900000	EA900001	EA900002	EA900003	EA900004	EA900005	EA900006
Lmax (A)	1	1.5	2.2	3.5	5	7.5	13
Fuse (A)	1.25	2.5	3.15	5	8	10	20
IP Rate	IP54	IP54	IP54	IP54	IP54	IP54	IP54

Wiring Diagram

Internally exchanging the faston clip connectors on the transformer, one can adjust the order of switching and the voltage corresponding to each step of the switch. Factory defaults:

VOLTAGE TAP	0	80	110	140	170	190	230
SWITCH POSITION			1	2	3	4	5

L-N - Power supply 230 VAC, 50/60 Hz
 L1 N1 - Unregulated output 230 VAC (2 A)
 N-U - Motor connection
 Pe - Earth connections

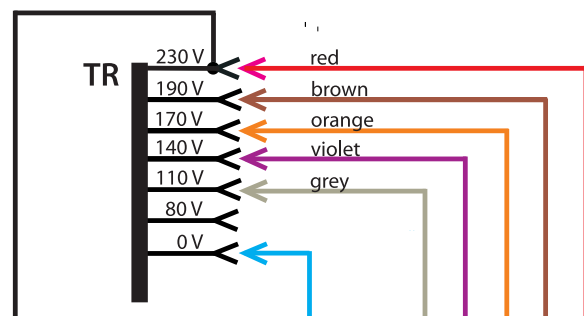

TEID1A

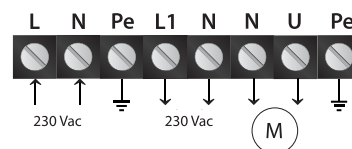

TEID1.5A-2.2A

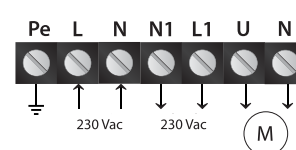

TEID3.5A-13A

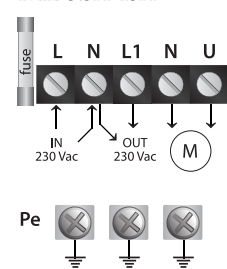

Dimensions & Weights

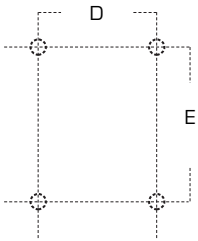
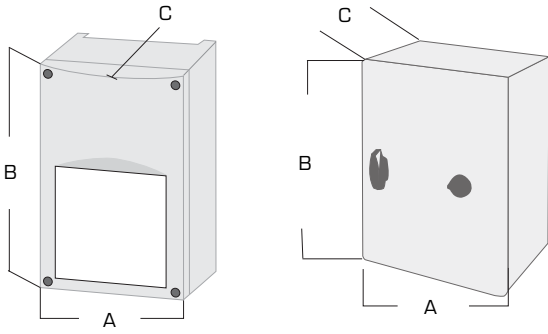

Model	A	B	C	D	E	Net. kg	Gross kg	Enclosure
TEID1A	84	160	88	71	108	1.2	1.3	Plastic
TEID1.5A	115	205	100	98	140	1.9	2.1	Plastic
TEID2.2A	115	205	100	98	140	2.1	2.3	Plastic
TEID3.5A	170	255	140	155	194	4.5	4.7	Plastic
TEID5A	170	255	140	155	194	5	5.4	Plastic
TEID7.5A	200	305	140	183	236	7.6	8	Plastic
TEID13A	300	185	185	255	255	14.8	15.3	Steel



General danger

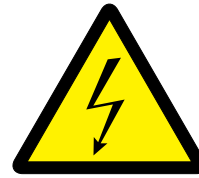

Electrical hazard

All works may only be carried out by skilled personnel following the local regulations and AFTER the controller is completely separated from the mains. Replace fuse only with same type and rating.

Mounting Instructions

Speed controller for single phase voltage controllable motors.

Mounting

Break (Isolate) mains voltage. The controllers are to be mounted on a smooth surface. Connect voltage supply, motor(s) and earth as shown in the scheme with cables of the proper diameter.

Wiring (Refer to diagram previously shown)

A safety isolator/switch disconnecter should be installed on the mains side of all motor drives; refer to SISO.

Motor protection

If motors are fitted with thermostat (Tk) overheat protection it is recommended to use the TEDS range to utilise this feature.

Transport and stock keeping

Avoid shocks and extreme conditions. Stock in original packing.

Warranty

Two years from delivery date against defects in manufacturing. Any modifications or alterations to the product relieve the manufacturer of all responsibility. The manufacturer bears no responsibility for any misprints or mistakes in this data, and modifications or improvements to the product can be made at any time after date of publication.

Maintenance

In normal conditions the controllers are maintenance-free. If soiled clean with dry or damp cloth. In case of heavy pollution clean with a non-aggressive product. In these circumstances the controller should be disconnected from the mains. Pay attention that no fluids enter the controller. Only reconnect the controller to the mains when it is completely dry.

TEDS – Transformer Single Phase

Demand Switched Drive



Features

- Switched control of fan speed. Five steps with off position
- Supply: 230 VAC, 50/60 Hz, 1 Phase
- IP54 ingress protection
- In built motor overheat protection via motor thermostats (Tk). Can be used for BMS fault.
- Switch: 5 positions with off-position
- BMS enable/disable (BMS fault via Tk)
- Indicator lights, on/fault
- Current fuse
- Auto reset after supply failure
- Run/stop contacts (CC - normally closed, CO - normally open, for thermostat/frost protection, PIR, BMS Enable/Disable)
- Ready mounted cable glands
- Enclosure: plastic (R-ABS, UL94-V0, RAL 7035); steel (RAL 7035, polyester powder coating)
- Maximum ambient temperature: 50 °C

Description

The TEDS transformer speed controllers are based on the principle of voltage control with auto-transformers. They are applicable to single phase voltage-controllable motors (230 VAC, 50/60 Hz) to control the rotational speed of fans in five steps.

They are fitted with contacts for motor thermostat (Tk) overheat protection (NC contacts). OC and CC inputs are provided for remote starting and stopping via thermostats, PIR and/or frost protection, etc.

A safety isolator/switch disconnecter should be installed on the mains side of all motor drives; refer to SISO.

Range

For selection of the correctly current rated drive select the model with a current rating equal to or above the fan full load current (FLC).

Model	TEDS1.5A	TEDS2.5A	TEDS3.5A	TEDS5A	TEDS7.5A	TEDS13A
Part	EA900007	EA900008	EA900009	EA900010	EA900011	EA900012
Lmax (A)	1.5	2.5	3.5	5.0	7.5	13
Fuse (A)	2.5	4	5	8	12.5	20
IP Rate	IP54	IP54	IP54	IP54	IP54	IP54

Wiring Diagram

Internally exchanging the faston clip connectors on the transformer, one can adjust the order of switching and the voltage corresponding to each step of the switch. Factory defaults:

VOLTAGE TAP	0	80	110	140	170	190	230
SWITCH POSITION			1	2	3	4	5

TEDS1.5A-7.5A

L-N - Power supply 230 VAC, 50/60 Hz

L1 - Unregulated output 230 VAC (2 A)

M-N - Motor connection

CC - Contact normally closed

OC - Contact normally open

TK - Connection for motor thermostat. Can be used for BMS fault.

N-AL - Alarm output (1 A)

Pe - Earth connections

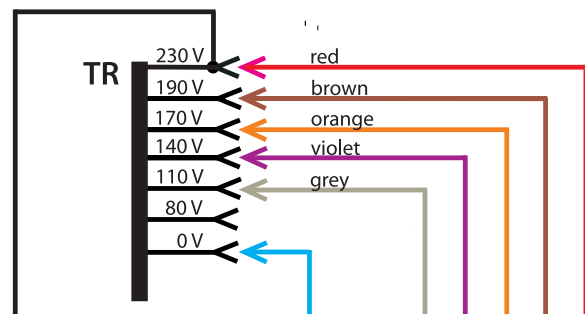

TEDS1.5A-7.5A

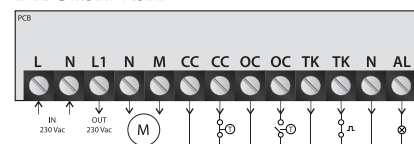

TEDS13A

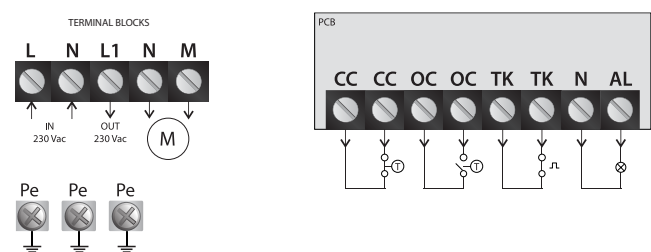

Dimensions & Weights

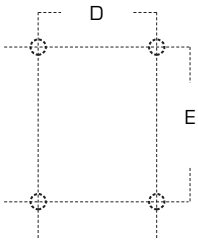
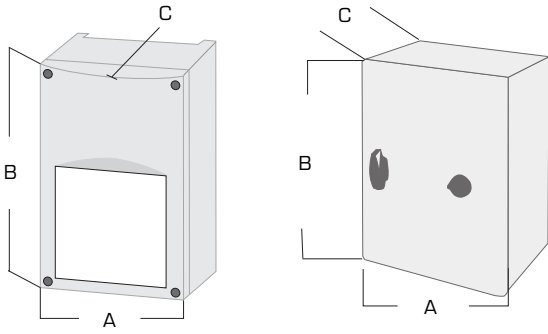

Model	A	B	C	D	E	Net kg	Gross kg	Enclosure
TEDS1.5A	170	255	140	155	194	3.6	3.9	Plastic
TEDS2.5A	170	255	140	155	194	3.6	3.9	Plastic
TEDS3.5A	170	255	140	155	194	4.6	4.9	Plastic
TEDS5A	170	255	140	155	194	5.6	5.9	Plastic
TEDS7.5A	200	305	155	183	236	8.3	8.7	Plastic
TEDS13A	300	325	185	255	255	16.4	16.9	Steel



General danger

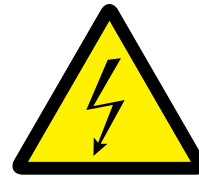

Electrical hazard

All works may only be carried out by skilled personnel following the local regulations and AFTER the controller is completely separated from the mains. Replace fuse only with same type and rating.

Mounting Instructions

Speed controller for single phase voltage controllable motors.

Mounting

Break (Isolate) mains voltage. The controllers are to be mounted on a smooth surface. Connect voltage supply, motor(s) and earth as shown in the scheme with cables of the proper diameter.

Wiring (see diagrams)

If TK-TK is not operational: Link TK-TK

A safety isolator/switch disconnecter should be installed on the mains side of all motor drives; refer to SISO.

Transport and stock keeping

Avoid shocks. Stock in original packing. Avoid extreme conditions.

Warranty

Two years from delivery date against defects in manufacturing. Any modifications or alterations to the product relieve the manufacturer of all responsibility. The manufacturer bears no responsibility for any misprints or mistakes in this data, and modifications or improvements to the product can be made at any time after date of publication.

Maintenance

In normal conditions the controllers are maintenance-free. If soiled clean with dry or damp cloth. In case of heavy pollution clean with a non-aggressive product. In these circumstances the controller should be disconnected from the mains. Pay attention that no fluids enter the controller. Only reconnect the controller to the mains when it is completely dry.

Motor protection

The TEDS are fitted with contacts for motor thermostat (Tk) overheat protection. When motor contacts open due to motors overheating, the circuit is broken and the controller stops the power to the motor. Reset by putting the switch in the "Off" position.

TEDSD – Transformer Single Phase

Demand Switched Dual Speed Drive



Features

- Switched control of fan speed between two speeds. Five steps with off position
- Supply: 230 VAC, 50/60 Hz, 1 Phase
- IP54 ingress protection
- In built motor overheat protection via motor thermostats (Tk). Can be used for BMS fault
- Switch: 5 positions with off-position & low/high
- BMS enable/disable
- Indicator light
- Run/stop contacts (CC - normally closed, OC –normally open) for PIR, thermostat etc.
- Enclosure: sheet steel (RAL 7035) / plastic (R-ABS, UL94-V0, RAL 7035)
- Maximum ambient temperature: 50 °C

Description

The TEDSD transformer speed controllers are based on the principle of voltage control with auto-transformers. They are applicable to voltage-controllable single phase motors (230 VAC, 50/60 Hz) to control the rotational speed of fans.

The TEDSD makes it possible to select two optimal motor speeds and to switch between these with a contact. Important energy savings and an increase of comfort can be realised e.g. through day/night, PIR, thermostat control.

The control is fitted with contacts for motor thermostat (Tk) overheat protection. Run/stop contacts (CC-closed/OC-open) for external or remote starting/stopping are also provided.

A safety isolator/switch disconnector should be installed on the mains side of all motor drive; refer to SISO.

Range

For selection of the correctly current rated drive select the model with a current rating equal to or above the fan full load current (FLC).

Model	TEDSD1.5A	TEDSD2.5A	TEDSD3.5A	TEDSD5A	TEDSD7.5A	TEDSD13A
Part	EA900013	EA900014	EA900015	EA900016	EA900017	EA900018
Lmax (A)	1.5	2.5	3.5	5.0	7.5	13
Fuse (A)	FT2.5	FT4	FT5	FT8	FT12.5	FT20
IP Rate	IP54	IP54	IP54	IP54	IP54	IP54

Wiring Diagram

- L-N - Power supply 230 VAC, 50/60 Hz
- L1 - Unregulated output 230 VAC (2 A)
- M-N - Motor connection
- CC - Contact normally closed
- OC - Contact normally open
- TK – Connection for motor thermostat. Can be used for BMS fault.
- N-AL - Alarm output (1 A)
- Pe - Earth connections

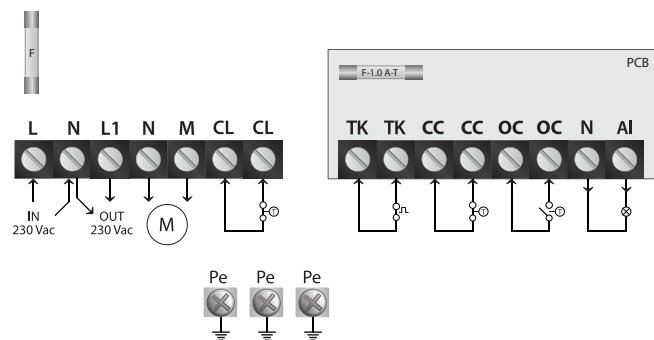
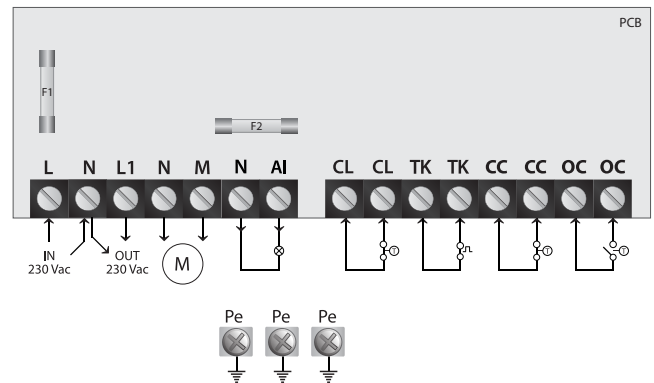

Dimensions & Weights

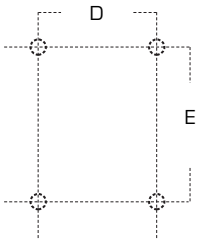
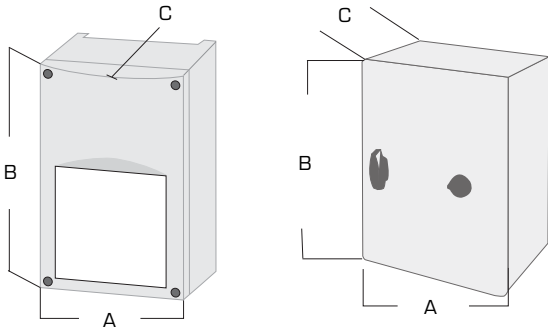

Model	A	B	C	D	E	Net kg	Gross kg	Enclosure
TEDSD1.5A	200	305	155	183	235	3.9	4.3	Plastic
TEDSD2.5A	200	305	155	183	235	4.4	4.8	Plastic
TEDSD3.5A	200	305	155	183	235	5.4	5.8	Plastic
TEDSD5A	200	305	155	183	235	6.2	6.5	Plastic
TEDSD7.5A	200	305	155	183	235	8.2	8.5	Plastic
TEDSD13A	300	425	175	255	355	17.6	18	Steel



General danger

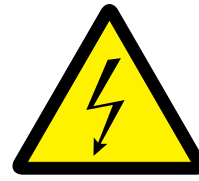

Electrical hazard

All works may only be carried out by skilled personnel following the local regulations and AFTER the controller is completely separated from the mains. Replace fuse only with same type and rating.

Mounting Instructions

Speed controller for single phase voltage controllable motors.

Mounting

Break (Isolate) mains voltage. The controllers are to be mounted on a smooth surface. Connect voltage supply, motor(s) and earth as shown in the scheme with cables of the proper diameter.

Wiring (see diagrams)

If TK-TK is not operational: Link TK-TK

A safety isolator/switch disconnecter should be installed on the mains side of all motor drives; refer to SISO.

Transport and stock keeping

Avoid shocks. Stock in original packing. Avoid extreme conditions.

Warranty

Two years from delivery date against defects in manufacturing. Any modifications or alterations to the product relieve the manufacturer of all responsibility. The manufacturer bears no responsibility for any misprints or mistakes in this data, and modifications or improvements to the product can be made at any time after date of publication.

Maintenance

In normal conditions the controllers are maintenance-free. If soiled clean with dry or damp cloth. In case of heavy pollution clean with a non-aggressive product. In these circumstances the controller should be disconnected from the mains. Pay attention that no fluids enter the controller. Only reconnect the controller to the mains when it is completely dry.

Motor protection

The TEDS are fitted with contacts for motor thermostat (Tk) overheat protection. When motor contacts open due to motors overheating, the circuit is broken and the controller stops the power to the motor. Reset by putting the switch in the "Off" position.

TEDP – Transformer Single Phase

Demand Proportional Drive



Features

- Proportional 5 step control of fan speed via 0-10VDC control signal
- Supply: 230 VAC, 50/60 Hz, 1 Phase
- IP54 ingress protection
- In built motor overheat protection via motor thermostats (Tk)
- Control signal input: 0-10 VDC Supply: 12 VDC e.g. CO₂, pressure and temperature sensor
- BMS enable/disable
- Indicator lights: run/fault
- Enclosure: plastic (R-ABS, UL94-V0, RAL 7035) or sheet steel (RAL 7035)
- Maximum ambient temperature: 50 °C

Description

The TEDP transformer speed controllers are based on the principle of voltage control with auto-transformers. They are applicable to single phase voltage-controllable motors (230 V, 50/60 Hz) to control the rotational speed of fans.

Each of the 5 transformer steps is selected with a 0-10 VDC signal, for example: combine with SDPV10, SDPV230 or other external signal.

TEDP drives are fitted connections for motors with thermostat (Tk) over-heat protection.

A safety isolator/switch disconnecter should be installed on the mains side of all motor drives; refer to SISO.

Range

For selection of the correctly current rated drive select the first model with a current rating above the fan full load current (FLC) to be controlled.

Model	TEDP1.5A	TEDP2.5A	TEDP3.5A	TEDP5A	TEDP7.5A	TEDP13A
Part	EA900019	EA900020	EA900021	EA900022	EA900023	EA900024
Lmax (A)	1.5A	2.5A	3.5A	5.0A	7.5A	13A
Fuse (A)	2.0A	3.15A	5A	8A	12.5A	20A
IP Rate	IP54	IP54	IP54	IP54	IP54	IP54

Wiring Diagram

Speed increases at: 2, 4, 6, 8, 9.5 VDC. Speed reduces at: 1.8, 3.8, 5.8, 7.8, 9.3 VDC

VOLTAGE TAP	0	80	110	140	170	190	230
SWITCH POSITION			1	2	3	4	5

L N - Power supply 230 VAC– 50/60 Hz

L1 N - Unregulated output 230 VAC (max. 2 A)

U N1 - Motor connection

TK - Input thermostat (Tk) from motor

0V - GND

+12V - Output 12 VDC/Imax = 50 mA (*Sum of the current for both outputs (+12V and +V) may not be greater than 100 mA)

+V - Digital output 12 VDC/ Imax = 50 mA* 0 V - TK fault 12 V - normal operation

V/C Input 0-10 VDC

Pe Earth connections

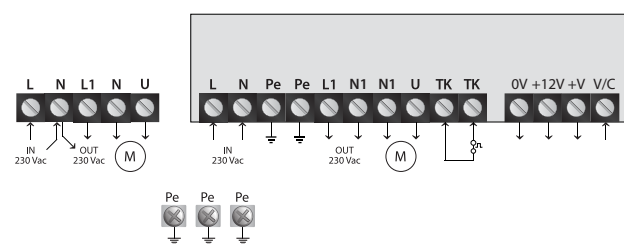
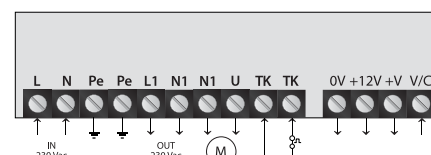
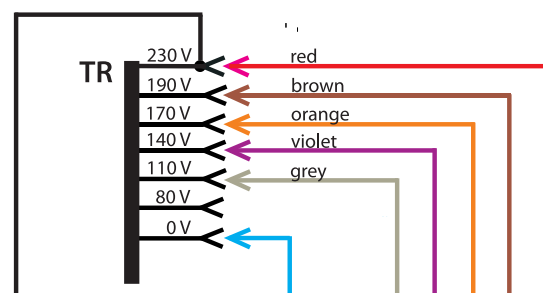
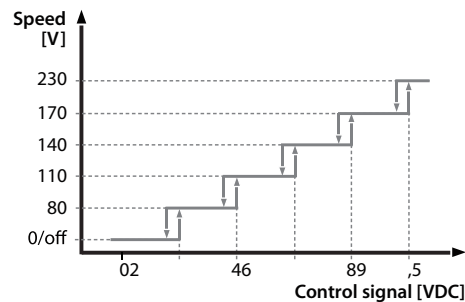

Dimensions & Weights

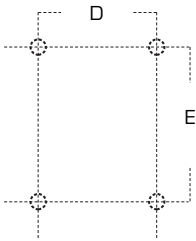
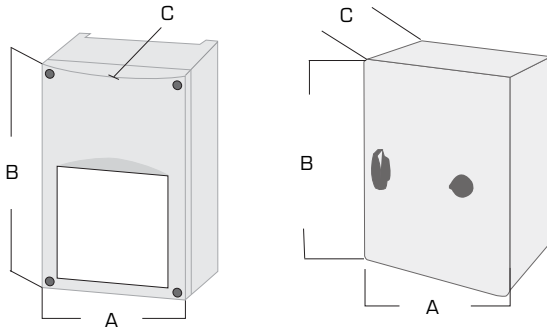

Model	A	B	C	D	E	Net kg	Gross kg	Enclosure
TEDP1.5A	200	305	140	183	236	4.4	5.7	Plastic
TEDP2.5A	200	305	140	183	236	4.5	4.8	Plastic
TEDP3.5A	200	305	140	183	236	5.7	6	Plastic
TEDP5A	200	305	140	183	236	6.4	6.7	Plastic
TEDP7.5A	200	305	140	183	236	8.6	8.9	Plastic
TEDP13A	300	325	170	255	255	15.9	16.2	Steel

Mounting Instructions

Speed controller for single phase voltage controllable motors.

Mounting

Break (Isolate) mains voltage. The controllers are to be mounted vertically on a smooth surface. Connect voltage supply, motor(s) and earth as shown in the scheme with cables of the proper diameter and in accordance with local regulations.

Wiring (see above diagram)

Connecting the input signal: a separate 0-10V signal is provided. In this case only 0V and V/C will be needed, connect negative line to the "0V" TB and the + or 0-10V to the "V/C" TB. The "+V" TB provides status feedback: Normal operation:12V (max 70 mA); Over temp fault: 0V.

If TK is not used: Link TK-TK

A safety isolator/switch disconnecter should be installed on the mains side of all motor drives; refer to SISO.

Transport and stock keeping

Avoid shocks and extreme conditions, stock in original packing.

Warranty

Two years from delivery date against defects in manufacturing. Any modifications or alterations to the product relieve the manufacturer of all responsibility. The manufacturer bears no responsibility for any misprints or mistakes in this data, and modifications or improvements to the product can be made at any time after date of publication.

Maintenance

In normal conditions the controllers are maintenance-free. If soiled clean with dry or damp cloth. In case of heavy pollution clean with a non-aggressive product. In these circumstances the controller should be disconnected from the mains. Pay attention that no fluids enter the

controller. Only reconnect the controller to the mains when it is completely dry.

Motor protection

The controller has connections for motors fitted with thermostat (Tk) overheat protection (NC contacts). Reset: disconnect and reconnect power.



General danger

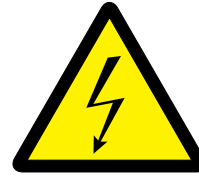

Electrical hazard

All works may only be carried out by skilled personnel following the local regulations and AFTER the controller is completely separated from the mains. Replace fuse only with same type and rating

Transformer Speed Controllers & Drives – Three Phase TDID – Transformer Three Phase Independent Drive



Features

- Independent 5 step transformer drive with motor overheat protection via thermostats
- Supply: 400 VAC, 50/60 Hz, 3 Phase
- IP54 ingress protection
- In built motor overheat protection via motor thermostats (Tk)
- Switch: 5 positions with off-position
- Indicator light
- 230 VAC unregulated output
- Enclosure: plastic (R-ABS, UL94-V0, RAL 7035) / sheet steel (RAL 7035)
- Maximum ambient temperature: 50 °C

Description

The TDID transformer speed controllers are based on the principle of voltage control with auto-transformers. They are applicable to three phase voltage-controllable motors (400 VAC, 50/60 Hz), to control the rotational speed of fans in five steps.

They are fitted out with contacts for motors equipped with thermostat (Tk) overheat protection.

A safety isolator/switch disconnecter should be installed on the mains side of all motor drives; refer to SISO.

Wiring Diagram

R S T - power supply 400 VAC– 50/60 Hz N - Neutral
L1 - unregulated output 230 VAC (2 A)
U V W - motor connection
TK - input thermal contacts of the motor
Pe - earth connections

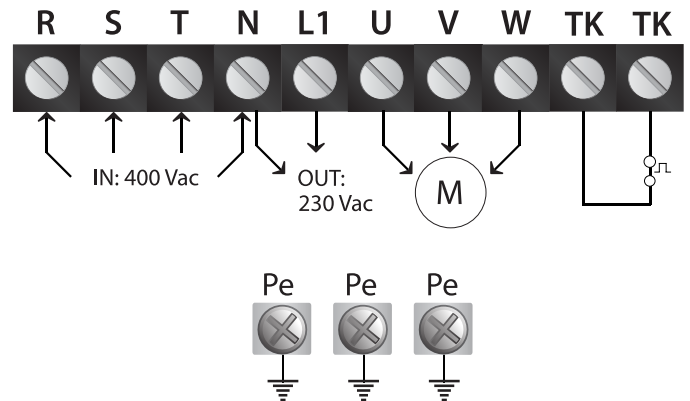

Range

For selection of the correctly current rated drive select the first model with a current rating above the fan full load current (FLC) to be controlled.

Model	TDID2.5A	TDID4A	TDID8A	TDID11A
Part	EA900025	EA900026	EA900027	EA900028
Lmax (A)	2.5	4	8	11
IP Rate	IP54	IP54	IP54	IP54

Dimensions & Weights

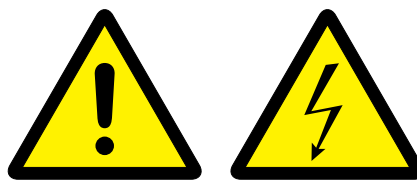
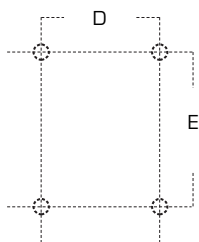
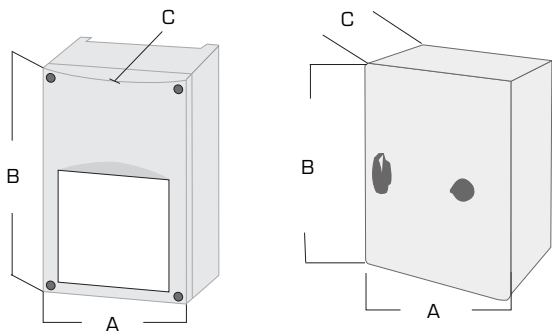

General danger

Electrical hazard

All works may only be carried out by skilled personnel following the local regulations and AFTER the controller is completely separated from the mains.

Model	A	B	C	D	E	Net kg	Gross kg	Enclosure
TDID2.5A	300	325	175	255	255	13.2	13.5	Steel
TDID4A	300	425	175	255	355	18.2	18.7	Steel
TDID8A	300	425	235	255	355	36.4	37	Steel
TDID11A	400	430	235	355	355	38.4	39	Steel

Mounting Instructions

Speed controller for three phase voltage controllable motors.

Mounting

Break (Isolate) mains voltage. The controllers are to be mounted on a smooth surface. Connect voltage supply, motor(s) and earth as shown in the scheme with cables of the proper diameter.

Wiring (see diagram on previous page)

A safety isolator/switch disconnecter should be installed on the mains side of all motor drives; refer to SISO.

Transport and stock keeping

Avoid shocks. Stock in original packing. Avoid extreme conditions.

Warranty

Two years from delivery date against defects in manufacturing. Any modifications or alterations to the product relieve the manufacturer of all responsibility. The manufacturer bears no responsibility for any misprints or mistakes in this data, and modifications or improvements to the product can be made at any time after date of publication.

Maintenance

In normal conditions the controllers are maintenance-free. If soiled clean with dry or damp cloth. In case of heavy pollution clean with a non-aggressive product. In these circumstances the controller should be disconnected from the mains. Pay attention that no fluids enter the controller. Only reconnect the controller to the mains when it is completely dry.

Motor protection

The controller has contacts for motors with thermostat (Tk) overheat protection (NC-contact). When motor overheating (or a power failure) is detected the controller stops power to the motor. The red indicator light and alarm output will signal this error condition. (Reset: main switch to off position and back).

TDDS – Transformer Three Phase

Demand Switched Drive



Features

- Switched 5 step transformer controller with motor thermostat (Tk) overheat protection
- Supply: 400 VAC, 50/60 Hz, 3 Phase
- IP54 ingress protection
- In built motor overheat protection via motor thermostats (Tk)
- Switch: 5 positions with off-position
- BMS enable/disable and fault
- Run/Stop contacts (CC - normally closed, OC – normally open) for remote control
- Enclosure: sheet steel (RAL 7035, polyester powder coating)
- Maximum ambient temperature: 50 °C

Description

The TDDS transformer speed controllers are based on the principle of voltage control with autotransformers. They are applicable to three phase voltage-controllable motors (400 VAC, 50/60 Hz), to control the rotational speed of fans in five steps.

They are fitted with contacts for motors with thermostat (Tk) overheat protection and run/stop contacts (CC-closed/OC-open) for external or remote starting and stopping via PIR, thermostats, BMS enable/disable etc.

A safety isolator/switch disconnecter should be installed on the mains side of the drive; refer to SISO.

Wiring Diagrams

R S T - power supply 400 VAC– 50/60 Hz
 N - Neutral
 L1 - unregulated output 230 VAC (2 A)
 U V W - motor connection
 TK - input thermal contacts of the motor
 CC - contact normally closed
 OC - contact normally open
 N-AL - alarm output (230 VAC/1 A)

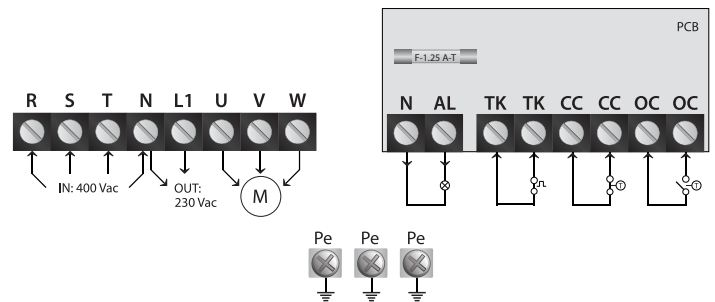

Range

For selection of the correctly current rated drive select the first model with a current rating above the fan full load current (FLC) to be controlled.

Model	TDDS2.5A	TDDS4A	TDDS8A	TDDS11A
Part	EA900029	EA900030	EA900031	EA900032
Lmax (A)	2.5	4	8	11
IP Rate	IP54	IP54	IP54	IP54

Dimensions & Weights

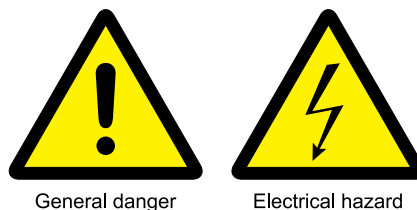
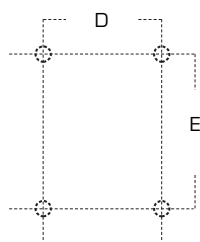
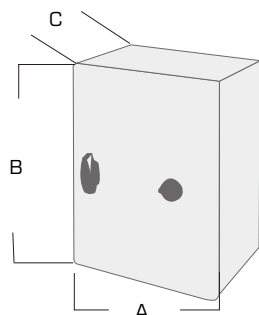

All works may only be carried out by skilled personnel following the local regulations and AFTER the controller is completely separated from the mains.

Model	A	B	C	D	E	Net kg	Gross kg	Enclosure
TDDS2.5A	300	325	175	255	255	13.4	13.9	Steel
TDDS4A	300	425	175	255	355	18.6	19.1	Steel
TDDS8A	300	425	235	255	355	27.9	28.4	Steel
TDDS11A	400	430	235	355	355	37.8	38.5	Steel

Mounting Instructions

Speed controller for three phase voltage controllable motors.

Mounting

Break (Isolate) mains voltage. The controllers are to be mounted on a smooth surface. Connect voltage supply, motor(s) and earth as shown in the scheme with cables of the proper diameter.

Wiring (see diagram on previous page)

A safety isolator/switch disconnecter should be installed on the mains side of all motor drives; refer to SISO.

Transport and stock keeping

Avoid shocks. Stock in original packing. Avoid extreme conditions.

Warranty

Two years from delivery date against defects in manufacturing. Any modifications or alterations to the product relieve the manufacturer of all responsibility. The manufacturer bears no responsibility for any misprints or mistakes in this data, and modifications or improvements to the product can be made at any time after date of publication.

Maintenance

In normal conditions the controllers are maintenance-free. If soiled clean with dry or damp cloth. In case of heavy pollution clean with a non-aggressive product. In these circumstances the controller should be disconnected from the mains. Pay attention that no fluids enter the controller. Only reconnect the controller to the mains when it is completely dry.

Motor protection

The controller has contacts for motors with thermostat (Tk) overheat protection (NC-contact). When motor overheating (or a power failure) is detected the controller stops power to the motor. The red indicator light and alarm output will signal this error condition. (Reset: main switch to off position and back).

TDDSD – Transformer Three Phase

Demand Switched Dual Speed Drive



Features

- Dual switched 5 step transformer control with motor thermostat (Tk) protection
- Supply: 400 VAC, 50/60 Hz, 3 Phase
- IP 54 ingress protection
- In built motor overheat protection via motor thermostats. Can be used for BMS fault.
- BMS enable/disable (BMS fault via Tk) Run/Stop contacts (CC, OC)
- Enclosure: sheet steel (RAL 7035, polyester powder coating)
- Maximum ambient temperature: 50 °C

Description

The TDDSD transformer speed controllers are based on the principle of voltage control with auto-transformers. They are applicable to three phase voltage-controllable motors (400 V, 50/60 Hz) to control the rotational speed of fans.

This controller makes it possible to select two optimal motor speeds and to switch these by a contact. Important energy savings and an increase of comfort can be realised. e.g. thermostat, PIR control.

They are fitted with connections for motor thermostat (Tk) overheat protection and run/stop contacts (CC-closed/OC-open) for external or remote starting e.g. PIR, thermostat, BMS enable/disable.

Range

For selection of the correctly current rated drive select the first model with a current rating above the fan full load current (FLC) to be controlled.

Model	TDDSD2.5A	TDDSD4A	TDDSD8A	TDDSD11A
Part	EA900033	EA900034	EA900035	EA900036
Lmax (A)	2.5	4	8	11
IP Rate	IP54	IP54	IP54	IP54

Wiring Diagrams

TDDSD2.5A

R S T - power supply 400 VAC, 50/60 Hz

N - Neutral

L1 - unregulated output 230 VAC (max 2 A)

U V W - motor connection

CL - contact normally closed (external clock – high/low switching)

TK - input thermal contacts of the motor

CC - contact normally closed

OC - contact normally open

N-AL - alarm output (230 VAC/1 A)

Pe - earth connections

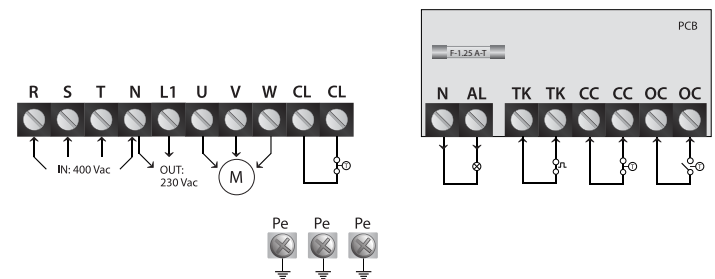
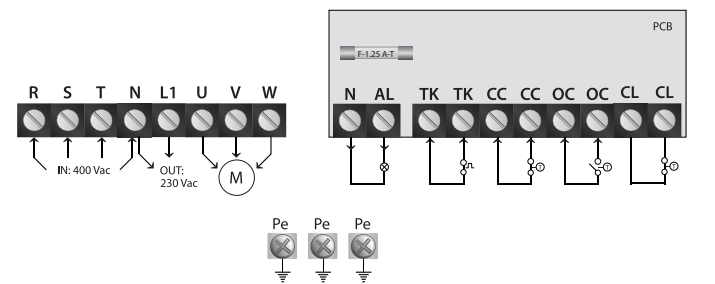

Dimensions & Weights

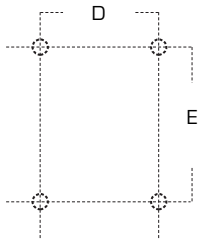
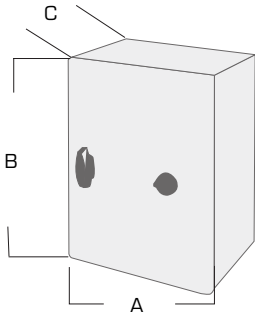

General danger

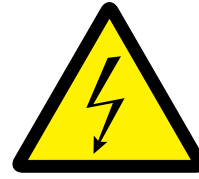

Electrical hazard

All works may only be carried out by skilled personnel following the local regulations and AFTER the controller is completely separated from the mains.

Model	A	B	C	D	E	Net kg	Gross kg	Enclosure
TDDSD2.5A	300	325	175	255	255	13.7	14	Steel
TDDSD4A	300	425	225	255	355	20.8	21.1	Steel
TDDSD8A	400	425	225	355	355	30.7	31	Steel
TDDSD11A	400	430	235	355	355	37.6	38	Steel

Mounting Instructions

Speed controller for three phase voltage controllable motors.

Mounting

Break (Isolate) mains voltage. The controllers are to be mounted on a smooth surface. Connect voltage supply, motor(s) and earth as shown in the scheme with cables of the proper diameter.

Wiring (see diagram on previous page)

A safety isolator/switch disconnecter should be installed on the mains side of all motor drives; refer to SISO.

Transport and stock keeping

Avoid shocks. Stock in original packing. Avoid extreme conditions.

Warranty

Two years from delivery date against defects in manufacturing. Any modifications or alterations to the product relieve the manufacturer of all responsibility. The manufacturer bears no responsibility for any misprints or mistakes in this data, and modifications or improvements to the product can be made at any time after date of publication.

Maintenance

In normal conditions the controllers are maintenance-free. If soiled clean with dry or damp cloth. In case of heavy pollution clean with a non-aggressive product. In these circumstances the controller should be disconnected from the mains. Pay attention that no fluids enter the controller. Only reconnect the controller to the mains when it is completely dry.

Motor protection

The controller has contacts for motors with thermostat (Tk) overheat protection (NC-contact). When motor overheating (or a power failure) is detected the controller stops power to the motor. The red indicator light and alarm output will signal this error condition. (Reset: main switch to off position and back).

TDDP – Transformer Three Phase

Demand Proportional Drive



Features

- Proportional 5 step transformer control with motor thermostat (Tk) overheat protection
- Supply: 400 VAC, 50/60 Hz, 3 Phase
- IP54 ingress protection
- In built motor overheat protection via motor thermostats (Tk)
- Control signal input: 0-10 VDC
Supply: 12 VDC e.g. CO₂ pressure and temperature sensor
- Supply: 12 VDC output
- BMS enable/disable
- Indicator lights: run/fault
- Enclosure: sheet steel (RAL 7035, polyester powder coating)
- Maximum ambient temperature: 50 °C

Description

The TDDP transformer speed controllers are based on the principle of voltage control with auto-transformers. They are applicable to three phase voltage-controllable motors (400 V, 50/60 Hz) to control the rotational speed of fans.

By combining the transformer outputs, contactors and a relay board, it is possible to select these predetermined speeds with a 0-10 VDC signal, for example: combine with SDPV10, SDPV230 or other external signal.

They are fitted with thermostat (Tk) contacts for motor protection and BMS enable/disable facilities.

A safety isolator/switch disconnecter should be installed on the mains side of all motor drives; refer to SISO.

Range

For selection of the correctly current rated drive select the first model with a current rating above the fan full load current (FLC) to be controlled.

Model	TDDP2.5A	TDDP4A	TDDP8A	TDDP11A
Part	EA900037	EA900038	EA900039	EA900040
Lmax (A)	2.5	4	8	11
IP Rate	IP54	IP54	IP54	IP54

Wiring Diagram

Speed goes up at: 2, 4, 6, 8, 9.5 VDC
Speed goes down at: 1.8, 3.8, 5.8, 7.8, 9.3 VDC

R S T - power supply 400 VAC- 50/60 Hz

L1 N - unregulated output 230 VAC (max 2 A)

U V W - motor connection

TK - input thermal contacts of the motor

0V - GND

+12V - output 12 VDC/Imax = 50 mA* * The sum of the current for both outputs (+12V and +V)

may not be greater than 100 mA

+V - digital output 12 VDC/Imax = 50 mA*

0 V = TK fault

12 V = normal operation

V/C input U: 0-10 VDC

Pe earth connections x3

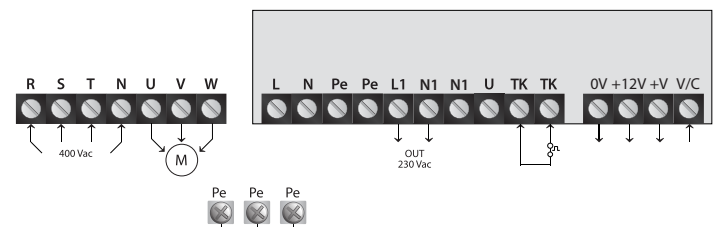

Dimensions & Weights

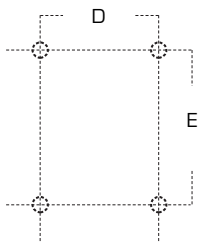
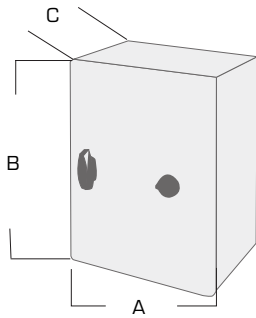

Model	A	B	C	D	E	Net kg	Gross kg	Enclosure
TDDP2.5A	300	425	170	255	355	17	17.5	Steel
TDDP4A	400	425	200	355	355	20	20.5	Steel
TDDP8A	400	425	200	355	355	27	27.5	Steel
TDDP11A	400	425	200	355	355	30	30.5	Steel

Mounting Instructions

Speed controller for three phase voltage controllable motors.

Wiring (Refer to diagram above)

When TK-TK not used: Connect TK-TK

A safety isolator/switch disconnecter should be installed on the mains side of all motor drives; refer to SISO.

Mounting

Break (Isolate) mains voltage. The controllers are to be mounted vertically on a smooth surface. Connect voltage supply, motor(s) and earth as shown in the scheme with cables of the proper diameter and in accordance with local regulations.

Transport and stock keeping

Avoid shocks and extreme conditions, stock in original packing.

Warranty

Two years from delivery date against defects in manufacturing. Any modifications or alterations to the product relieve the manufacturer of all responsibility. The manufacturer bears no responsibility for any misprints or mistakes in this data, and modifications or improvements to the product can be made at any time after date of publication.

Maintenance

In normal conditions the controllers are maintenance-free. If soiled clean with dry or damp cloth. In case of heavy pollution clean with a non-aggressive product. In these circumstances the controller should be disconnected from the mains. Pay attention that no fluids enter the controller. Only reconnect the controller to the mains when it is completely dry.

Motor protection

In built motor overheat protection via motor thermostats (Tk). When these contacts open because of motor overheating, this circuit is broken and the controller stops power to the motor. There is NO

automatic restart for safety reasons. After elimination of the cause of the overheating, restart by putting the switch in Off-position for a few moments.



General danger

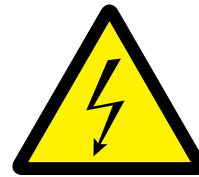

Electrical hazard

All works may only be carried out by skilled personnel following the local regulations and AFTER the controller is completely separated from the mains.

Inverter Speed Control & Drives IDDXB20 – Inverter Three Phase IP20

Demand Independent, Switched and Proportional Drive – For Tube/Box Fans



Features

- 400V, 1.2-15.5A, 0.37-7.5kW 3 Ph
- Enclosure IP20
- Max shielded cable length 25m
- Asynch motor control
- Simple installation wizard
- Ultra compact
- Alpha-numeric display
- Included potentiometer for manual speed adjustment & thermistor overheat protection
- Built in RFI allowing for 15m of screen cable
- Built-in brake functions with built in DC and AC brake functions
- 2xAI, 1xAO & 1xRO / RS485. Connectable as Modbus RTU
- BMS enable/disable
- Maximum ambient 50°C

Description

IDDXB20 is a three phase frequency converter with unsurpassed reliability, user-friendliness, condensed functionality, and extremely easy to commission. Terminal numbers are named in the same manner as in the rest of the family.

IDDXB20 can be set up to perform perfectly even in complex application set-ups. It is specifically configured for installation close to tube and box fans.

Independent drive, from the front potentiometer, switched and proportional demand control are included as standard.

A safety isolator/switch disconnecter should be installed on the mains side of all motor drives; refer to SISO.

Description	Part
Local Control Panel(LCP11) Digital Keypad w/out Pot.	EA901057
Local Control Panel(LCP12) Digital Keypad with Pot.	EA901058
Local Control Panel mtg kit (inc. 3m cable)	EA901059
NEMA Type 1 kit M1	EA901060
NEMA Type 1 kit M1	EA901061
NEMA Type 1 kit M1	EA901062
Decoupling plate for M1 & M2	EA901063
Decoupling plate for M3	EA901064
IP21 for M1 frame	EA901065
IP21 for M2 frame	EA901066
IP21 for M3 frame	EA901067
DIN rail kit for M1 frame	EA901068

Wiring Diagram

For detail please refer to the specific diagrams supplied with each drive.

Range

For selection of the correctly current rated drive select the first model with a current rating above the fan full load current (FLC) to be controlled.

Model	Ph.	V	IP	Amps	kW	FWG Part	Enc.
IDDXB-20-1.2	3-3	380-440V	20	1.2	0.37	EA901042	M1
IDDXB-20-2.2	3-3	380-440V	20	2.2	0.75	EA901043	M1
IDDXB-20-3.7	3-3	380-440V	20	3.7	1.5	EA901044	M2
IDDXB-20-5.3	3-3	380-440V	20	5.3	2.2	EA901045	M2
IDDXB-20-7.2	3-3	380-440V	20	7.2	3.0	EA901046	M3
IDDXB-20-9	3-3	380-440V	20	9	4.0	EA901047	M3
IDDXB-20-12	3-3	380-440V	20	12	5.5	EA901048	M3
IDDXB-20-15.5	3-3	380-440V	20	15.5	7.5	EA901049	M3

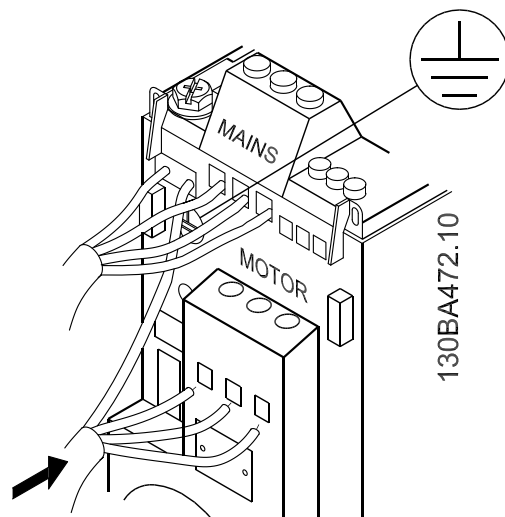

Dimensions & Weights

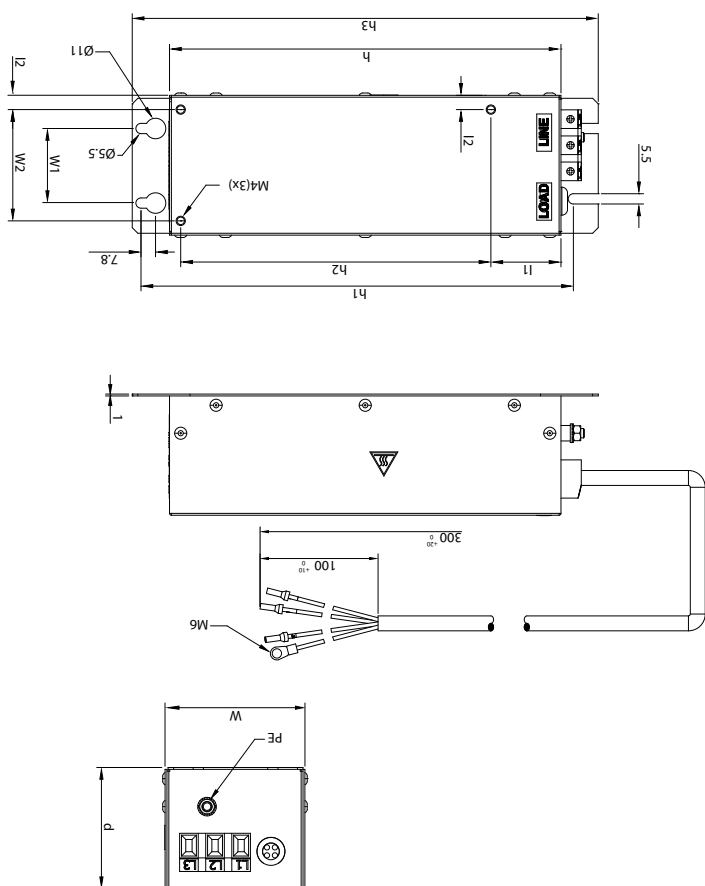

Frame	M1	M2	M3	Unit
w	70	75	90	mm
d	55	65	69	mm
h	190	210	300	mm
h3	230	250	340	mm
w1	40	40	55.6	mm
h1	213	233	323	mm
w2	55	59	69	mm
h2	140	166.5	226	mm
l1	45	38.5	68	mm
l2	7.6	8	9.3	mm
PE	M6	M6	M6	metric
Weight	2	3	5	kg

Mounting Instructions

Please refer to the specific instructions & software supplied with each drive.



General danger

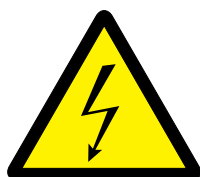

Electrical hazard

All works may only be carried out by skilled personnel following the local regulations, reference to the installation guide and AFTER the controller is completely separated from the mains.

Inverter Speed Control & Drives IDDXF20 – HVAC Inverter Three Phase IP20

Demand Independent, Switched and Proportional Drive – For Axial & Centrifugal Fans



Features

- 400V, 1.2-90A, 0.37-90W 3 Ph
- Designed for HVAC applications i.e. Fire mode, Flying Start...
- Enclosures IP20 (see IDDXF54 for IP54 and IDDXF66 for IP66)
- Asynch & PM motor control. Max shielded cable length 25m
- Simple installation wizard, Alpha-numeric display
- Alpha-numeric display
- In built motor overheat protection via motor thermistors
- EMC A1/C2 integrated filters & DC choke for harmonic mitigation
- 4xDI, 2xAI, 1xAO/DO & 2xRO/RS485 BMS enable/disable Modbus RTU, N2, FLN & BACnet
- Maximum ambient 50°C

Description

Designed specifically for fan applications the three phase IDDXF Frequency converters control speed, torque, and the overall performance of AC & PM motors by controlling the power input.

Independent, Switched and Proportional demand control from the included digital, and HVAC protocols ensures maximum efficiency and comfort to the level required.

A safety isolator/switch disconnecter should be installed on the mains side of all motor drives; refer to SISO.

Description	FWG Part
Local Control Panel	EA901031
Local Control Panel mounting kit inc. 3m cable	EA901032
Decoupling plate H1 & H2	EA901033
Decoupling plate H3	EA901034
Decoupling plate H4 & H5	EA901035
IP21 option H1	EA901036
IP21 option H2	EA901037
IP21 option H3	EA901038
IP21 option H4	EA901039
IP21 option H5	EA901040

Range

For selection of the correctly current rated drive select the first model with a current rating above the fan full load current (FLC) to be controlled.

Model	Ph.	V	IP	Amps	kW	FWG Part	Enc.
IDDXF-20-1.2	3-3	400V	20	1.2	0.37	EA901000	H1
IDDXF-20-2.2	3-3	400V	20	2.2	0.75	EA901001	H1
IDDXF-20-3.7	3-3	400V	20	3.7	1.5	EA901002	H1
IDDXF-20-5.3	3-3	400V	20	5.3	2.2	EA901003	H2
IDDXF-20-7.2	3-3	400V	20	7.2	3.0	EA901004	H2
IDDXF-20-9	3-3	400V	20	9	4.0	EA901005	H2
IDDXF-20-12	3-3	400V	20	12	5.5	EA901006	H3
IDDXF-20-15.5	3-3	400V	20	15.5	7.5	EA901007	H3
IDDXF-20-23	3-3	400V	20	23	11.0	EA901008	H4
IDDXF-20-31	3-3	400V	20	31	15.0	EA901009	H4
IDDXF-20-37	3-3	400V	20	37	18.5	EA901010	H5
IDDXF-20-42.5	3-3	400V	20	42.5	22.0	EA901011	H5
IDDXF-20-61	3-3	400V	20	61	30.0	EA901012	H6
IDDXF-20-73	3-3	400V	20	73	37.0	EA901013	H6
IDDXF-20-90	3-3	400V	20	90	45.0	EA901014	H6

Wiring Diagram

For detail please refer to the specific diagrams supplied with each drive.

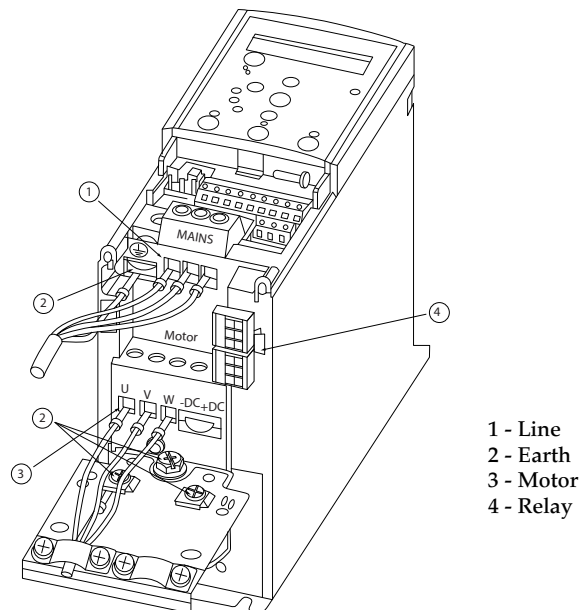

- 1 - Line
- 2 - Earth
- 3 - Motor
- 4 - Relay

Dimensions & Weights

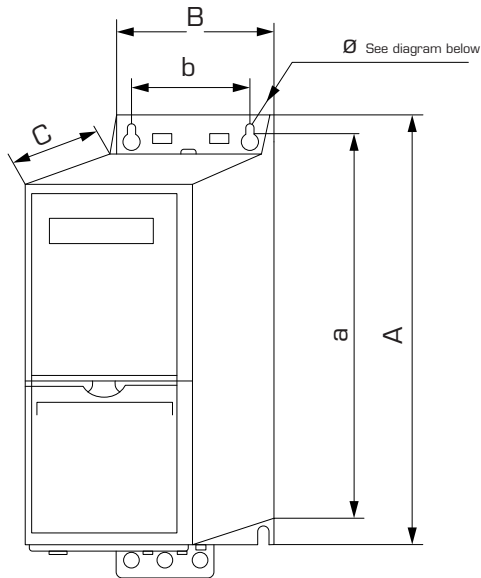

Mounting Instructions

Please refer to the specific instructions & software supplied with each drive.



General danger

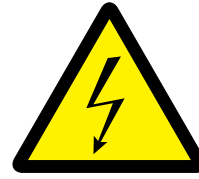

Electrical hazard

All works may only be carried out by skilled personnel following the local regulations, reference to the installation guide and AFTER the controller is completely separated from the mains.

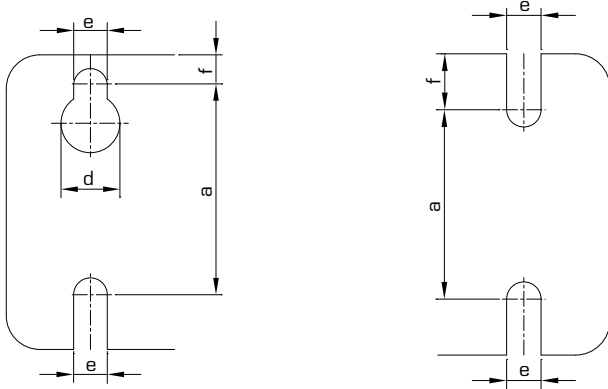

Enclosure	Power [kW]		Height [mm]		Width [mm]		Depth [mm]	Mounting hole [mm]			Max Weight [kg]			
	Frame	IP Class	3x 380-480 V	3x 525-600 V	A	"A incl Decoupling Plate"		B	b	C		d	e	f
H1	IP20	0.37-1.5			195	273	183	75	56	168	9	4.5	5.3	2.1
H2	IP20	2.2-4.0			227	303	212	90	65	190	11	5.5	7.4	3.4
H3	IP20	5.5-7.5			255	329	240	100	74	206	11	5.5	8.1	4.5
H4	IP20	11-15			296	359	275	135	105	241	12.6	7	8.4	7.9
H5	IP20	18.5-22			334	402	314	150	120	255	12.6	7	8.5	9.5
H6	IP20	30-45	18.5-30		518	595/635 (45 kW)	495	239	200	242	-	8.5	15	24.5
H7	IP20	55-75	37-55		550	630/690 (75 kW)	521	313	270	335	-	8.5	17	36
H8	IP20	90	75-90		660	800	631	375	330	335	-	8.5	17	51
H9	IP20		2.2-7.5		269	374	257	130	110	205	11	5.5	9	6.6
H10	IP20		11-15		399	419	380	165	140	248	12	6.8	7.5	12

Inverter Speed Control & Drives

IDDXF54 – HVAC Inverter Three Phase IP54

Demand Independent, Switched and Proportional Drive – For Axial & Centrifugal Fans



Features

- 400V, 2.2-177A, 0.75-90kW 3 Ph
- Designed for HVAC applications i.e. Fire mode, Flying Start...
- Enclosures IP54 (see IDDXF20 for IP20 and IDDXF66 for IP66)
- Asynch & PM motor control. Max shielded cable length 25m
- Simple installation wizard. Alpha-numeric display
- In built motor overheat protection via motor thermistors
- EMC A1/C2 integrated filters & DC choke for harmonic mitigation
- 4xDI, 2xAI, 1xAO/DO & 2xRO / RS485. Modbus RTU, N2, FLN & BACnet
- Maximum ambient 50°C

Description

Designed specifically for three phase fan applications the IDDXF Frequency converters control speed, torque, and the overall performance of AC & PM motors by controlling the power input. Independent, Switched and Proportional demand control from the included digital, and HVAC protocols ensures maximum efficiency and comfort to the level required.

A safety isolator/switch disconnecter should be installed on the mains side of all motor drives; refer to SISO.

Description	FWG Part
Local Control Panel	EA901031
Local Control Panel mounting kit inc. 3m cable	EA901032
Decoupling plate H1 & H2	EA901033
Decoupling plate H3	EA901034
Decoupling plate H4 & H5	EA901035
IP21 option H1	EA901036
IP21 option H2	EA901037
IP21 option H3	EA901038
IP21 option H4	EA901039
IP21 option H5	EA901040

Range

Model	Ph.	V	IP	Amps	kW	FWG Part	Enc.
IDDXF-54-2.2	3-3	400V	54	2.2	0.75	EA901016	I2
IDDXF-54-3.7	3-3	400V	54	3.7	1.5	EA901017	I2
IDDXF-54-5.3	3-3	400V	54	5.3	2.2	EA901018	I2
IDDXF-54-7.2	3-3	400V	54	7.2	3.0	EA901019	I2
IDDXF-54-9	3-3	400V	54	9	4.0	EA901020	I2
IDDXF-54-12	3-3	400V	54	12	5.5	EA901021	I3
IDDXF-54-15.5	3-3	400V	54	15.5	7.5	EA901022	I3
IDDXF-54-23	3-3	400V	54	23	11.0	EA901023	I4
IDDXF-54-31	3-3	400V	54	31	15.0	EA901024	I4
IDDXF-54-37	3-3	400V	54	37	18.5	EA901025	I4
IDDXF-54-42.5	3-3	400V	54	42.5	22.0	EA901026	I6
IDDXF-54-61	3-3	400V	54	61	30.0	EA901027	I6
IDDXF-54-73	3-3	400V	54	73	37.0	EA901028	I6
IDDXF-54-90	3-3	400V	54	90	45.0	EA901029	I7
IDDXF-54-106	3-3	400V	54	106	55.0	EA901069	I7
IDDXF-54-147	3-3	400V	54	147	75.0	EA901070	I8
IDDXF-54-177	3-3	400V	54	177	90.0	EA901071	I8

Wiring Diagram

For detail please refer to the specific diagrams supplied with each drive.

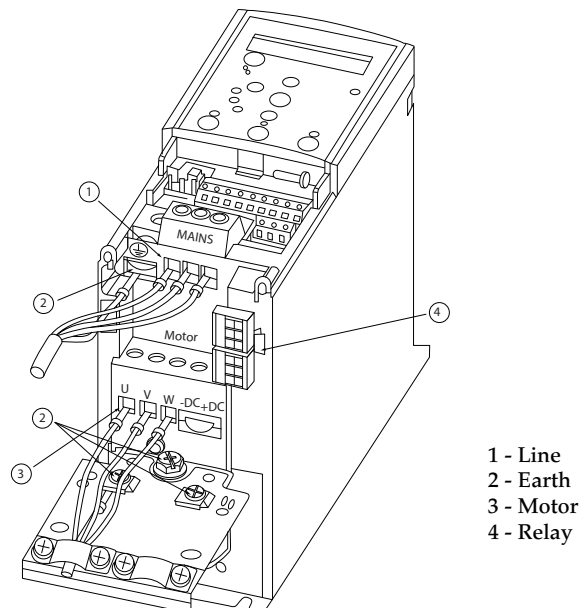

- 1 - Line
- 2 - Earth
- 3 - Motor
- 4 - Relay

Dimensions & Weights

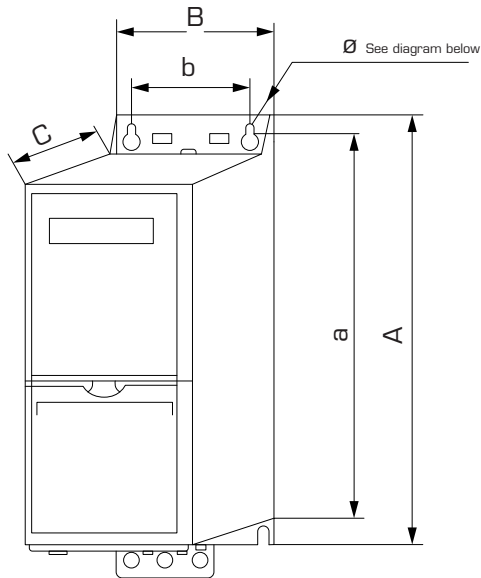

Mounting Instructions

Please refer to the specific instructions & software supplied with each drive.



General danger

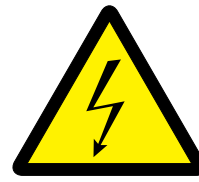

Electrical hazard

All works may only be carried out by skilled personnel following the local regulations, reference to the installation guide and AFTER the controller is completely separated from the mains.

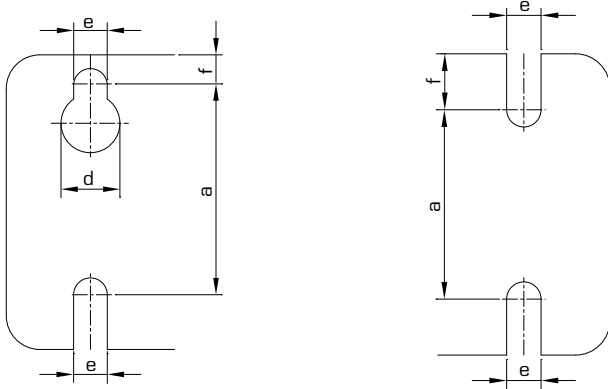

Enclosure	Power [kW]	Height [mm]	Width [mm]	Depth [mm]	Mounting hole [mm]	Max Weight						
Frame	IP Class	3x 380-480 V	A	*A incl Decoupling Plate*	a	B	b	C	d	e	f	kg
12	IP54	0.75-4.0	332	-	318.5	115	74	225	11	5.5	9	5.3
13	IP54	5.5-7.5	368	-	354	135	89	237	12	6.5	9.5	7.2
14	IP54	11-18.5	476	-	460	180	133	290	12	6.5	9.5	13.8
15	IP54	11-18.5	480	-	454	242	210	260	19	9	9	23
16	IP54	22-37	650	-	624	242	210	260	19	9	9	27
17	IP54	45-55	680	-	648	308	272	310	19	9	9.8	45
18	IP54	75-90	770	-	739	370	334	335	19	9	9.8	65

Inverter Speed Control & Drives IDDXF66 – HVAC Inverter Three Phase IP66

Demand Independent, Switched and Proportional Drive – For Axial & Centrifugal Fans



Features

- 400V, 3.0-106A, 1.1-55kW 3 Ph
- Designed for HVAC applications i.e. Fire mode, Flying Start...
- Enclosures IP66 ingress protection
- Max shielded cable length 25m
- Asynch & PM motor control
- Simple installation wizard
- Ultra compact
- Alpha-numeric display
- In built motor overheat protection via motor thermistors
- LCP Remote mounting kit with 3m cable available
- Connectable to all major HVAC protocols Modbus RTU, N2, FLN & BACnet
- EMC A1/C2 integrated filters & DC choke for harmonic mitigation
- 4xDI, 2xAI, 1xAO/DO & 2xRO / RS485
- BMS enable/disable
- Fully programmable set points via display & included software
- Maximum ambient 50°C
- High energy efficiency

Description

Designed specifically for three phase fan applications the IDDXF Frequency converters control speed, torque, and the overall performance of AC & PM motors by controlling the power input.

Independent, Switched and Proportional demand control from the included digital, and HVAC protocols ensures maximum efficiency and comfort to the level required.

A safety isolator/switch disconnecter should be installed on the mains side of all motor drives; refer to SISO.

Wiring Diagram

For detail please refer to the specific diagrams supplied with each drive.

Range

Model	Ph.	V	IP	Amps	kW	FWG Part	Enc.
IDDXF-66-3	3-3	400V	66	3	1.1	EA901072	A4
IDDXF-66-4.1	3-3	400V	66	4.1	1.5	EA901073	A4
IDDXF-66-5.6	3-3	400V	66	5.6	2.2	EA901074	A4
IDDXF-66-7.2	3-3	400V	66	7.2	3	EA901075	A4
IDDXF-66-9	3-3	400V	66	9	4	EA901076	A4
IDDXF-66-12	3-3	400V	66	12	5.5	EA901077	A5
IDDXF-66-15.5	3-3	400V	66	15.5	7.5	EA901078	A5
IDDXF-66-23	3-3	400V	66	23	11	EA901079	B1
IDDXF-66-31	3-3	400V	66	31	15	EA901080	B1
IDDXF-66-37	3-3	400V	66	37	18.5	EA901081	B1
IDDXF-66-42.5	3-3	400V	66	42.5	22	EA901082	B2
IDDXF-66-61	3-3	400V	66	61	30	EA901083	B2
IDDXF-66-73	3-3	400V	66	73	37	EA901084	C1
IDDXF-66-90	3-3	400V	66	90	45	EA901085	C1
IDDXF-66-106	3-3	400V	66	106	55	EA901086	C1

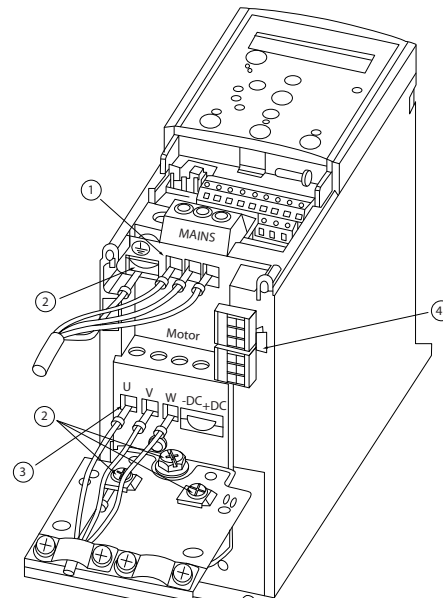

- 1 - Line
- 2 - Earth
- 3 - Motor
- 4 - Relay

Dimensions & Weights

Frame size (kW):	A4	A5	B1	B2	C1
380-480V	1.1-40	1.1-7.5	11-18.5	22-30	37-55
IP	/66	/66	/66	/66	/66
Height (mm)					
Enclosure	390	420	480	650	680
...with de-coupling plate	-	-	-	-	-
Back plate	390	420	480	650	680
Distance between mount. Holes	401	402	454	624	648
Width (mm)					
Enclosure	200	242	242	242	308
With one C option		242	242	242	308
Back plate	200	242	242	242	308
Distance between mount. Holes	171	215	210	210	272
Depth (mm)					
Without option A/B	175	200	260	260	310
With option A/B	175	200	260	260	310
Screw holes (mm)					
	8.2	8.2	12	12	12
Diameter ø	12	12	19	19	19
Diameter ø	6.5	6.5	9	9	9
	6	9	9	9	9.8
Max Weight (kg)	9.7	14	23	27	45

Mounting Instructions

Please refer to the specific instructions & software supplied with each drive.



General danger

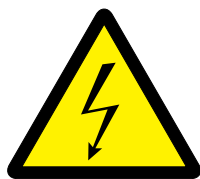

Electrical hazard

All works may only be carried out by skilled personnel following the local regulations, reference to the installation guide and AFTER the controller is completely separated from the mains.

Inverter Speed Control & Drives

IEDXB20 – Inverter Single to Three Phase IP20

Demand Independent, Switched and Proportional Drive – For Tube/Box Fans



Features

- 1x200-240VAC to 3x200-240VAC, 1.2-9.6A, 0.18-2.2kW
- Enclosure IP20
- Max shielded cable length 25m
- Asynch motor control
- Simple installation wizard
- Ultra compact
- Alpha-numeric display
- Included fitted potentiometer for manual speed adjustment
- Connectable as Modbus RTU
- Built in RFI
- Built-in brake functions with built in DC and AC brake functions
- 2xAI, 1xAO & 1xRO / RS485
- BMS enable/disable
- Maximum ambient 50°C
- Coated PCB standard for harsh environments
- High energy efficiency

Description

IEDXB20 is a frequency converter with unsurpassed reliability, user-friendliness, condensed functionality, and extremely easy to commission. Terminal numbers are named in the same manner as in the rest of the family.

It converts single phase 200-240VAC input to three phase output for areas limited by power supply availability and efficiency requirements.

Independent drive, from the front potentiometer, switched and proportional demand control are included as standard.

A safety isolator/switch disconnecter should be installed on the mains side of the drive; refer to SISO.

Ensure motor is suitable for 200-240VAC 3 phase operation.

Range

Model	Ph.	V	IP	Amps	kW	FWG Part	Enc.
IEDXB-20-1.2	1-3	200-240V	20	1.2	0.18	EA901050	M1
IEDXB-20-2.2	1-3	200-240V	20	2.2	0.37	EA901051	M1
IEDXB-20-4.2	1-3	200-240V	20	4.2	0.75	EA901052	M2
IEDXB-20-6.8	1-3	200-240V	20	6.8	1.5	EA901053	M2
IEDXB-20-9.6	1-3	200-240V	20	9.6	2.2	EA901054	M3

Accessories

Description	Part
Local Control Panel(LCP11) Digital Keypad w/out Pot.	EA901057
Local Control Panel(LCP12) Digital Keypad with Pot.	EA901058
Local Control Panel mgt kit (inc. 3m cable)	EA901059
Decoupling plate for M1 & M2	EA901063
Decoupling plate for M3	EA901064
IP21 for M1 frame	EA901065
IP21 for M2 frame	EA901066
IP21 for M3 frame	EA901067
DIN rail kit for M1 frame	EA901068

Wiring Diagram

For detail please refer to the specific diagrams supplied with each drive.

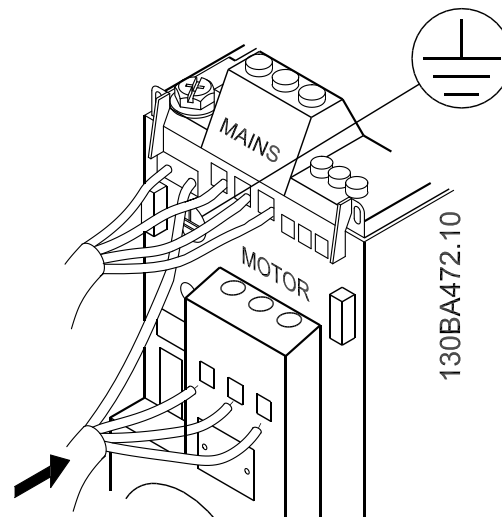

Dimensions & Weights

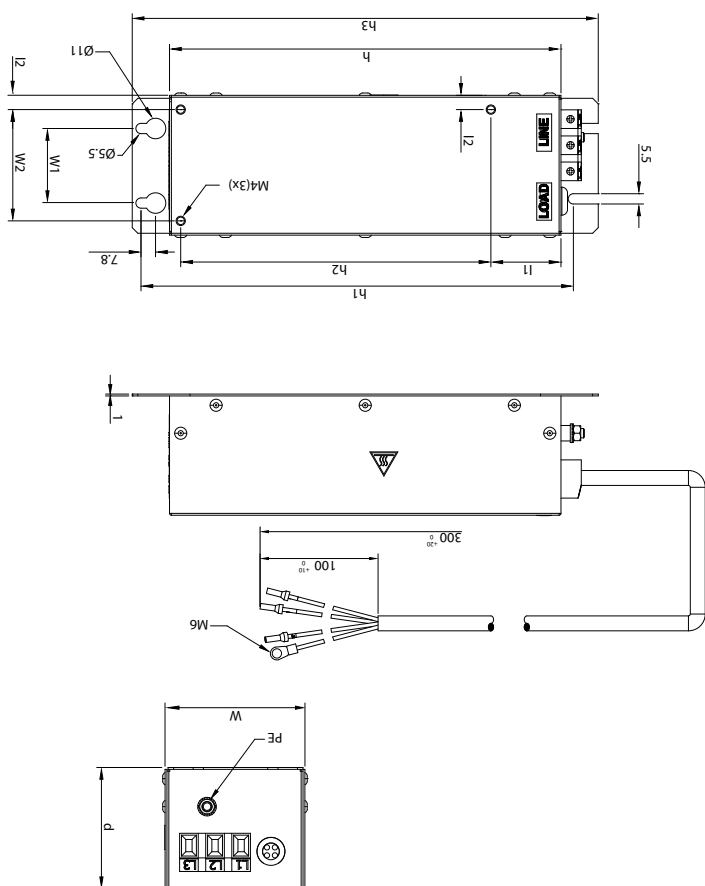

Frame	M1	M2	M3	Unit
w	70	75	90	mm
d	55	65	69	mm
h	190	210	300	mm
h3	230	250	340	mm
w1	40	40	55.6	mm
h1	213	233	323	mm
w2	55	59	69	mm
h2	140	166.5	226	mm
l1	45	38.5	68	mm
l2	7.6	8	9.3	mm
PE	M6	M6	M6	metric
Weight	2	3	5	kg

Mounting Instructions

Please refer to the specific instructions & software supplied with each drive.



General danger

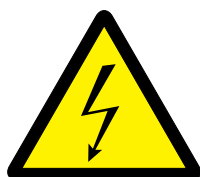

Electrical hazard

All works may only be carried out by skilled personnel following the local regulations, reference to the installation guide and AFTER the controller is completely separated from the mains.

Isolation Switches

SISO – Safety Isolators/Switch-Disconnectors



Features

- Electrical range 230V-690V, 1-3phase, 50-60Hz, 0-63A
- Enclosure IP66 Grey RAL 7035
- Mechanically interlocked with 3xPadlock to 'Off' apertures
- Early breaker fitted to all units as standard. Three and Six pole/wire versions available
- Three and Six pole/wire versions available
- Two entries top and bottom 20/25A M20 40/63A M20/25
- Stainless steel fascia screws
- Two earth continuity screws in each enclosure

Description

All fans and drives should have a correctly rated lockable isolation switch installed in the power input circuit to provide full electrical isolation. This is vital for safe installation, operation and maintenance.

Many modern drives also require an early break signal so that a graceful full power off can be achieved without damage to sensitive electronics. Early break is included in all SISO Isolators. Isolators are provided with mechanically interlocked IP66 as standard.



Auxiliary Contacts			
Rated insulation	V	690	
Rated thermal current	A	10	
	100V	A	8
	220-240V	A	8
Operational current	380-400V	A	3
	660-690V	A	1
	Max. conductor size	mm ²	1.5
Tightening torque	Nm	0.6	

Wiring Diagram

0 - I (90° indexing)

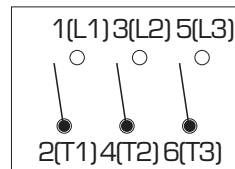

2 & 3 Pole

0 - I (90° indexing)

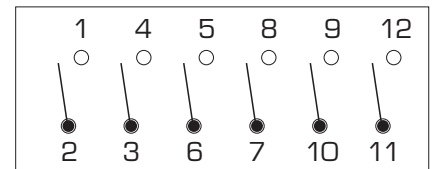

6 Pole

Range

Model	Description	Part
SISO25-3	Isolator 3P 25A+2EB	EAO02000
SISO40-3	Isolator 3P 40A+2EB	EAO02001
SISO63-3	Isolator 3P 63A+2EB	EAO02002
SISO25-6	Isolator 6P+2EB 25A	EAO02003
SISO40-6	Isolator 6P+2EB 40A	EAO02004

Attribute	Unit	SISO25-3	SISO40-3	SISO63-3	SISO20-6	SISO40-6
Rated thermal current	A	25	40	63	20	40
Rated insulation voltage	V	690	690	690	690	690
Rated impulse voltage	kV	6.0	6.0	6.0	6.0	6.0
Rated operational power (3 phase AC)	kW	11.0	15.0	25.0	7.5	15.0
Rated short withstand current (1 sec)	A	500	600	1300	250	800
Terminal type						
Flexible cable	mm ²	6.0	6.0	16.0	2.5x2	6.0x2
Rigid cable	mm ²	10.0	10.0	25.0	2.5x2	10.0x2
Tightening torque	Nm	1.2	1.2	1.2	1.0	1.0

Dimensions & Weights

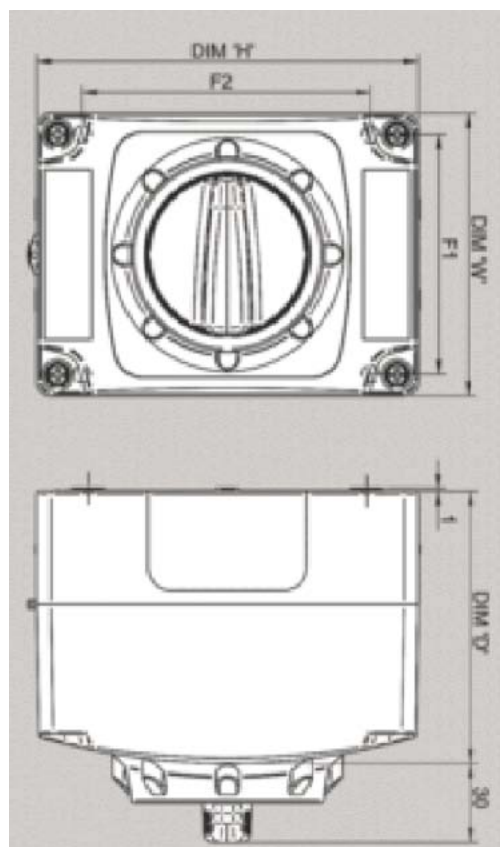

Amps	H (mm)	W (mm)	D (mm)	F1 (mm)	F2 (mm)	Ø (mm)
20/25A	135	100	95	85	98.5	5.5
40/63A	175	130	115	115	135	5.5

Mounting Instructions

This product shall be installed, commissioned and maintained by or under the supervision of a competent electrician in accordance with current electrical engineering Codes of practice and regional laws.

It is essential that the power supply is disconnected prior to installation.

To maintain the IP rating to the product it is important to adhere to the following,

- Use only the existing mounting holes
- Use cable glands and sealing washers designed to maintain the rating
- Tighten lid screws to 1.2Nm

The unit designed to be mounted vertically.

Ensure that the correct cross section of cable and terminators are used as the table above.



General danger

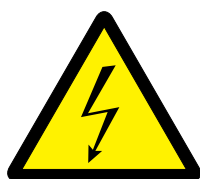

Electrical hazard

All works may only be carried out by skilled personnel following the local regulations, reference to the installation guide and AFTER the controller is completely separated from the mains.

SDXT – Room Temperature Sensor/Switch Controller

for Demand Proportional & Switched Drives

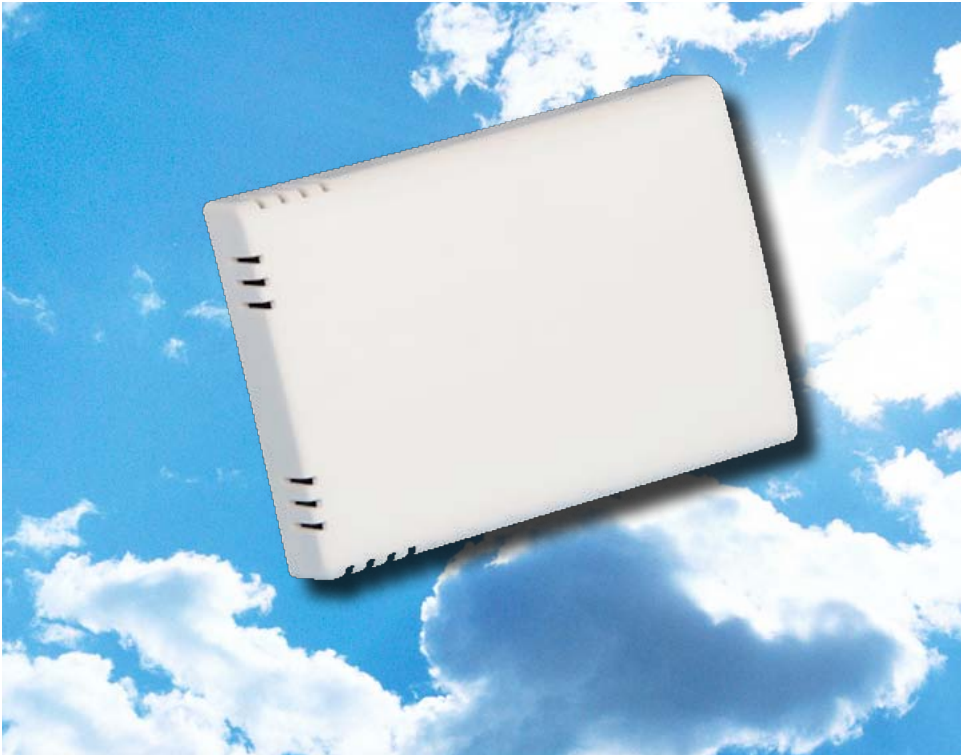

Features

- Supply voltage: 18-32 VDC $\pm 10\%$ / 15-24 Vac $\pm 10\%$
- Low profile housing with covered screws
- Terminal blocks with 0.75 mm² connectors
- Measurement range -0 +40°C
- Accuracy: $\pm 0,5\text{ }^{\circ}\text{C}$
- Short reaction times: less than 2 sec. in air
- LED operating indication
- Enclosure: plastic ABS, V0, RAL9010 ivory
- Protection class: IP30
- Power consumption: up to 60 mA
- Sensor element: platinum temperature sensor PT500
- Analogue output 0-10 Vdc/0-20 mA
- Digital relay output
- Modbus RTU on board
- Downloadable set-up software

Description

These room temperature sensors provide precision sensing, compatible with all leading control systems. They are designed to provide fast response to changes in thermal comfort conditions. Each unit is equipped with a platinum sensor and has a 0-10 Vdc/0-20 mA analogue output and relay digital signal.

They include on board Modbus RTU and although pre-set for normal operations can be site set via downloadable software.

Wiring Diagram

- A - RS485 signal A
- /B - RS485 signal /B
- GND - ground
- AO1 - analogue output
- GND - ground
- +V 15-24 VAC $\pm 10\%$ / 18-34 VDC $\pm 10\%$
- GND - ground
- NC1 - relay output - normally closed (230 VAC/2 A)
- COM1 - relay output - common (230 VAC/2 A)
- NO1 - relay output - normally open (230 VAC/2 A)

Range

Model	Description	Part
SDXT	Room Temperature Sensor/Switch controller with Modbus RTU	EAD02100

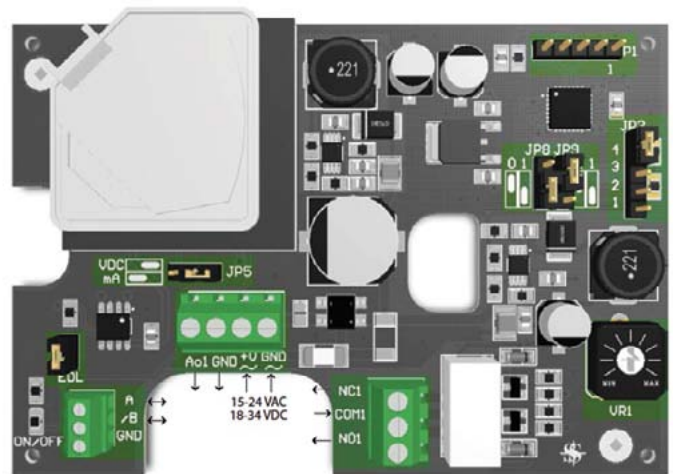

Dimensions & Weights

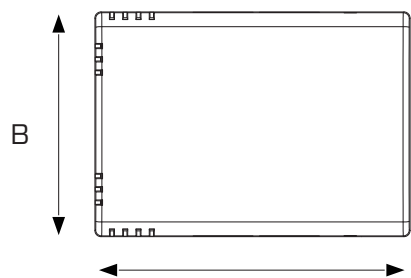
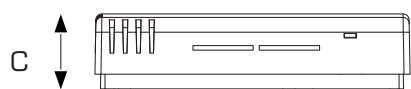

A

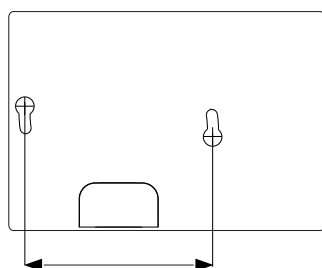

D

Amps	A (mm)	B (mm)	C (mm)	D (mm)	Net (g)	Grosst (g)
SDXT	105	75	26	60	110	120

Mounting Instructions

Technical data

Supply voltage: 18-32 VDC $\pm 10\%$ / 15-24 VAC $\pm 10\%$

Operating temperature range: -10...50 °C

Relay output: 230 VAC/2 A

Enclosure: plastic ABS, V0, RAL9010 ivory,

Ingress Protection: IP30

Wiring (see previous page)

Mounting

The device is to be mounted in a room on a smooth surface, preferably at a minimum height of 1.50 m above the floor.

Transport and stock keeping

Avoid shocks. Stock in original packing. Avoid extreme conditions.

Warranty

Two years from delivery date against defects in manufacturing. Any modifications or alterations to the product relieve the manufacturer of all responsibility. The manufacturer bears no responsibility for any misprints or mistakes in this data, and modifications or improvements to the product can be made at any time after date of publication.

Maintenance

In normal conditions the controllers are maintenance-free. If soiled clean with dry or damp cloth. In case of heavy pollution clean with a non-aggressive product. In these circumstances the controller should be disconnected from the mains. Pay attention that no fluids enter the controller. Only reconnect the controller to the mains when it is completely dry.



General danger

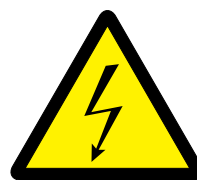

Electrical hazard

All works may only be carried out by skilled personnel following the local regulations, reference to the installation guide and AFTER the controller is completely separated from the mains.

SDXC – Room CO₂ Sensor/Switch Controller

for Demand Proportional & Switched Drives



Features

- Supply voltage: 15-24VAC or 18-34VDC
- Microcontroller based design increases accuracy and reduces installation time
- Modbus RTU (RS485)
- Software for configuration
- IP30 Ingress protection
- LED operation indication
- Excellent long term stability with NDIR CO₂ sensor
- Innovative self-calibrating algorithm
- Sensor and switch combined
- C/O relay output
- Analogue output: 0-10 VDC/0-20 mA
- Different CO₂ ranges selectable by jumper or via Modbus
- Setpoint selectable by trimmer
- Operating conditions: -10 to 50 °C and 0-95 % RH

Description

These CO₂ sensor/switches provide a stable, secure environment with high energy performance.

The concentration of CO₂ in the air is measured (with four predefined ranges or a user-definable range), using a self-calibrated and maintenance-free sensor with NDIR technology.

The SDXC is fully configurable via Modbus RTU RS485 communications and is compatible with most building management systems. Although pre-set, software is made freely available for after sales configuration.

Range

Model	Description	Part
SDXC	Room CO ₂ Sensor/Switch controller with Modbus RTU	EAC02101

Wiring Diagram

- A - RS485 signal A
- /B - RS485 signal /B
- GND - ground
- AO1 - analogue output
- GND - ground
- +V 15-24 VAC ±10 %/18-34 VDC ±10 %
- GND - ground
- NC1 - relay output - normally closed (230 VAC/2 A)
- COM1 - relay output - common (230 VAC/2 A)
- NO1 - relay output - normally open (230 VAC/2 A)

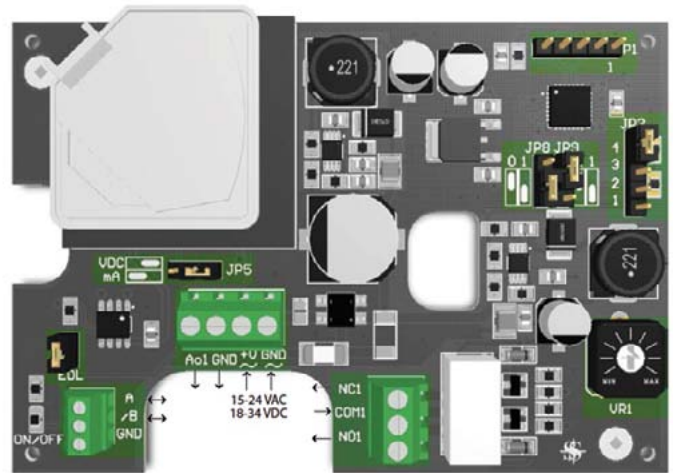

Settings

Jumper reset Modbus settings



J1	
	Put and hold the jumper on position 1 for 20 sec

Jumper analog output



JP5	Output
	0-10 VDC
	0-20 mA

Jumper hysteresis value

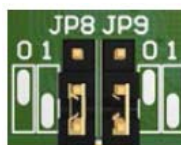

JP8 JP9	Hysteresis
	25 ppm
	50 ppm
	75 ppm
	100 ppm

Jumper sensor range

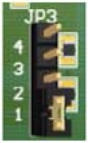

1	2	3	4	5	Sensor range
0	0	0	0	0	0-2.000 ppm
0	0	0	1	0	0-1.500 ppm
0	0	1	0	0	0-1.000 ppm
0	1	0	0	0	450-1.850 ppm

Jumper Network Bus Termination Resistor



EOL	Resistor
0	connected
1	disconnected

Trimmer setpoint



MIN: minimum of the sensor range
MAX: maximum of the sensor range

Settings

Operation Graph

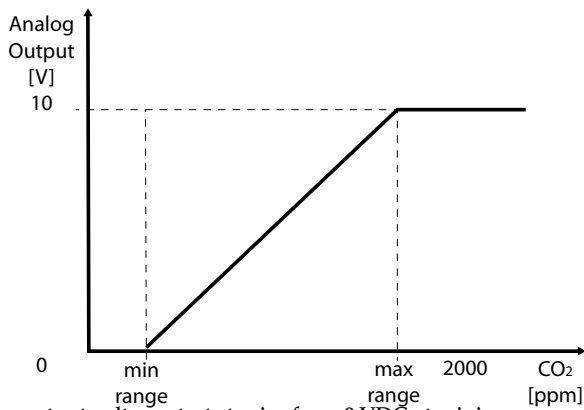

The output voltage starts to rise from 0 VDC at minimum sensor range and reaches 10 VDC at maximum sensor range.

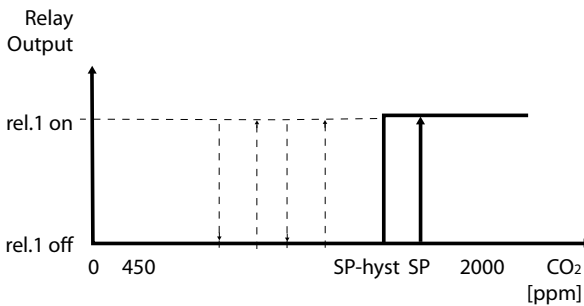

The relay switches on at an adjusted setpoint by trimmer and switches off again with an adjusted hysteresis selected by jumpers.

Input Registers (read)

	Data Type	Description	Data	Values
1		Reserved, returns 0		
2		Reserved, returns 0		
3		Reserved, returns 0		
4	CO ₂ ppm	Actual CO ₂ , level	2.000-2.000 ppm	
5		Reserved, returns 0		
6		Reserved, returns 0		
7		Reserved, returns 0		
8		Reserved, returns 0		
9		Reserved, returns 0		
10		Reserved, returns 0		

	Data Type	Description	Data	Values
11	Analog output	signed int.	Actual analog output value	0-1.000 1.000=10.00 VDC
12	Relay status	signed int.	Actual status of relay	0 1 = on
13	CO ₂ range	signed int.	Actual CO ₂ , range active selected by jumper holding register	1 (450-1850 ppm) 2 (0-1.000 ppm) 3 (0-1.500 ppm) 4 (0-2.000 ppm)
14	CO ₂ set point	signed int.	Actual CO ₂ , setpoint active setpoint selected by trimmer or holding register	2.000=2.000 ppm
15	Hysteresis	signed int.	Hysteresis for relay, selectable by jumpers	25 50 75 100 50=50ppm
16	Setpoint out of range flag	signed int.	Flag that shows when setpoint is out of sensor range	0=OK 1 = setpoint out of range
17	Calibration timer	unsigned int.	Returns passed in % for 10 min calibration procedure in progress, if in active returns 0	0-100 0-100%
18			Reserved, returns 0	
19			Reserved, returns 0	
20			Reserved, returns 0	

Holding Registers (Read/Write)

	Data Type	Description	Data	Values	
1	Device address	unsigned int.	Device address	1-247 (default: 1) 1-9.600	
2	RS485 baud rate	unsigned int.	Modbus communication baud rate	2=19.200 (default) 3=38.400 4=57.600	
3	RS485 parity mode	unsigned int.	Parity check mode	0=8N1 1=8E1 2=8O1 (default)	
4	Device type	unsigned int.	Device type, read-only	RXC-G=2	
5	HW Version	signed int.	Hardware version of the device, read-only	XXX 300 = HW version 3.00	
6	SW Version	signed int.	Software version of the device, read-only	XXX 130 = SW version 1.30	
7	Modbus Control	signed int.	Enables Modbus control and disables jumpers and trimmers	0=disable 1=enable	
8	Modbus direct control	signed int.	Enables direct control over outputs	0=disable 1=enable	
9			Reserved, returns 0		
10			Reserved, returns 0		
11	CO ₂ range	signed int.	CO ₂ range selection	1 (default) 2 3 4 5 1 (450-1850 ppm) 2 (0-1.000 ppm) 3 (0-1.500 ppm) 4 (0-2.000 ppm) 5 custom	
12	CO ₂ custom range min	signed int.	CO ₂ custom range min	0-max (default:0)	1.000 = 1.000 ppm
13	CO ₂ custom range max	signed int.	CO ₂ custom range max	min - 2.000 (default:2.000)	2.000 = 2.000 ppm
14	CO ₂ setpoint	signed int.	Setpoint for CO ₂ relay		2.000 = 2.000 ppm
15	10 minute calibration	signed int.	Setting this to 1 will perform 10 minute calibration and will automatically be cleared after calibration, the sensor measures CO ₂ level for 10 min. and sets the lowest value at 400ppm (do not switch off during this procedure!)	0 (default) 1	1 = 10 min. calibration active
16	1 month calibration	signed int.	Setting this to 1 will turn on 1 month calibration and is not automatically cleared after the calibration, the sensor measures CO ₂ level for 1 month and sets the lowest value at 400 ppm (do not switch off during this procedure!)	0 (default) 1	1 = 1 month calibration active
17			Reserved, returns 0		
18			Reserved, returns 0		
19			Reserved, returns 0		
20			Reserved, returns 0		
21	Analog output override	signed int.	Override value, active only if registers 7 and 8 are set to '1'	0-1.000 (default:0)	0=0.00 VDC 1.000=10.00 VDC
22			Reserved, returns 0		
23			Reserved, returns 0		
24			Reserved, returns 0		
25			Reserved, returns 0		
26			Reserved, returns 0		
27			Reserved, returns 0		
28			Reserved, returns 0		
29			Reserved, returns 0		
30			Reserved, returns 0		

Coils (Read/Write)

Data Type	Description
1 - Relay 1 bit	Available only if holding registers 7 and 8 and set to '1'

Dimensions & Weights

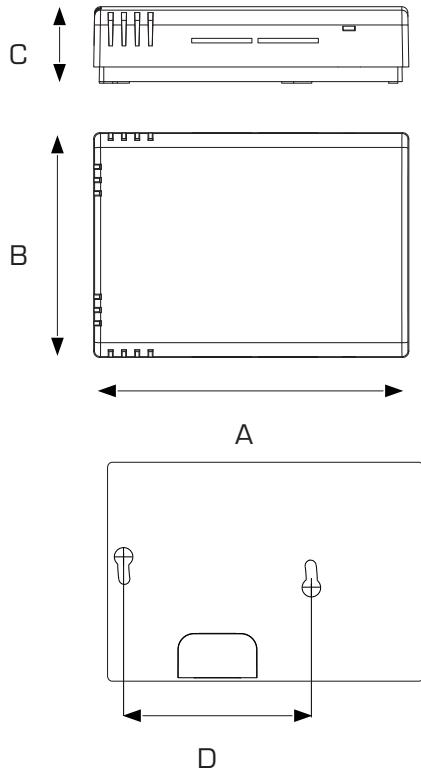

Model	A (mm)	B (mm)	C (mm)	D (mm)	Net (g)	Gross (g)
SDXC	105	75	26	60	110	120

Mounting Instructions

Technical data

Supply voltage: 18-32 VDC $\pm 10\%$ / 15-24 VAC $\pm 10\%$

Power consumption normal: up to 75 mA, peak: 400 mA for 10 ms per 3 sec period

Accuracy: ± 50 ppm

Operating temperature range: -10...50 °C

Relay output: 230 VAC/2 A

Enclosure: plastic ABS, V0, RAL9010 ivory,

Ingress Protection: IP30

The CO₂ room sensor/switch measures the concentration of CO₂ from 450 to 1850 ppm in air using a NDIR sensor which is self-calibrating and maintenance-free in a normal environment.

Wiring (see diagram on previous page)

Mounting

The device is to be mounted in a room on a smooth surface, preferably at a minimum height of 1.50 m above the floor.

Transport and stock keeping

Avoid shocks. Stock in original packing. Avoid extreme conditions.

Warranty

Two years from delivery date against defects in manufacturing. Any modifications or alterations to the product relieve the manufacturer of all responsibility. The manufacturer bears no responsibility for any misprints or mistakes in this data, and modifications or improvements to the product can be made at any time after date of publication.

Maintenance

In normal conditions the controllers are maintenance-free. If soiled clean with dry or damp cloth. In case of heavy pollution clean with a non-aggressive product. In these circumstances the controller should be disconnected from the mains. Pay attention that no fluids enter the controller. Only reconnect the controller to the mains when it is completely dry.



General danger

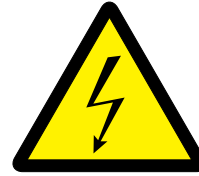

Electrical hazard

All works may only be carried out by skilled personnel following the local regulations, reference to the installation guide and AFTER the controller is completely separated from the mains.

SDSI – Room Passive Infrared Switch

for Demand Switched Drives (PIR)



Features

- Input voltage: 25VDC
- Relay Output: OC 250V 2A
- Nominal Max Range: 15m
- Flush mounting in standard wall box

Description

The SDSI passive infrared (PIR) switch is ideal for mounting in a standard wall backing box. Three adjustment pots allow for delay, sensitivity and range to be adjusted ensuring that the controlling relay only closes when the room or space is occupied.

Range

Model	Description	Part
SDSI	Room Passive Infrared for switched output (PIR)	EAD02102

Wiring Diagram

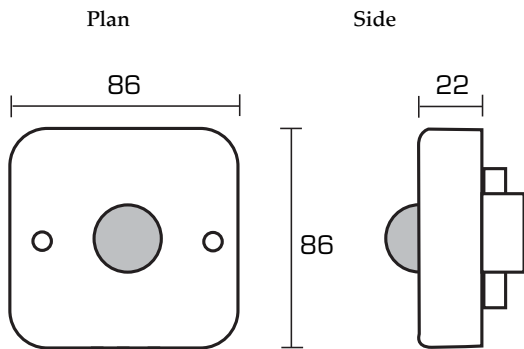

Mounting Instructions

Technical data
 Supply voltage: 18-32 VDC $\pm 10\%$
 Power consumption normal: up to 75 mA, peak: 400 mA for 10 ms per 3 sec period
 Operating temperature range: -10 to 50 °C
 Relay output: 250 VAC 2A
 Enclosure: plastic ABS, V0, Ivory,
 Ingress Protection: IP30

Wiring (see diagram)

Mounting

The device is to be mounted in a room on a smooth surface, preferably at a minimum height of 1.50 m above the floor.

Transport and stock keeping

Avoid shocks. Stock in original packing. Avoid extreme conditions.

Warranty

Two years from delivery date against defects in manufacturing. Any modifications or alterations to the product relieve the manufacturer of all responsibility. The manufacturer bears no responsibility for any misprints or mistakes in this data, and modifications or improvements to the product can be made at any time after date of publication.

Maintenance

In normal conditions the controllers are maintenance-free. If soiled clean with dry or damp cloth. In case of heavy pollution clean with a non-aggressive product. In these circumstances the controller should be disconnected from the mains. Pay attention that no fluids enter the controller. Only reconnect the controller to the mains when it is completely dry.



All works may only be carried out by skilled personnel following the local regulations, reference to the installation guide and AFTER the controller is completely separated from the mains

SDSP54 – Pressure Switch

for Demand Switched Drives



Features

- Max. operating pressure: 10 KPa for all pressure ranges
- Operating temperature: -20 to 85 °C
- Storage temperature -40 to 85 °C
- Contacts rating: 250 VAC, 1.5 A
- IP Protection: 54
- Mechanical life cycles: +10 million operations
- Materials: Diaphragm: Silicone, Case: PA 6.6 and POM

Description

These adjustable highly sensitive differential pressure switches are used for monitoring over pressure, vacuum and differential pressure of air or other non-combustible, non-aggressive gases.

The switching set-point can be adjusted by means of a calibrated knob.

Possible applications are air filters, fan monitoring, overheat protection for electric elements, controlling air- and fire-protection dampers, monitoring air flows and more.

Drawing

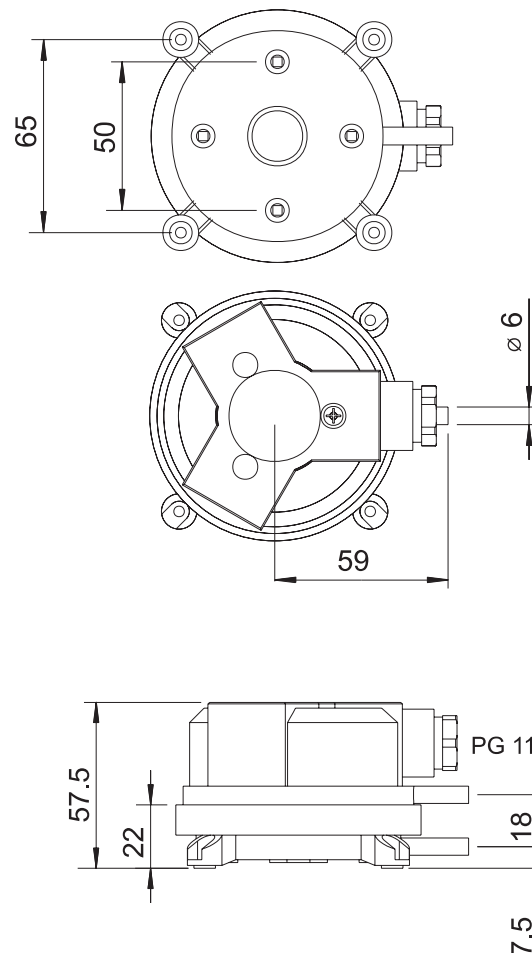

Range

Model	Description	Part
SDSP54-500	Pressure switch 50-500Pa DP Pa 20	EAO02103
SDSP54-1000	Pressure switch 200-1000Pa DP Pa 100	EAO02104

Wiring Diagram

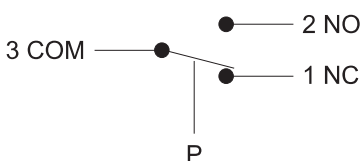

1. Break contact
2. Operating contact
3. Power

Mounting Instructions

Differential pressure switch

Technical data

Range Pa

PSW-500: 50-500

PSW-1000: 200-1000

Max. operating pressure 50 mBar or 5000 Pa

Operating temperature -20 - 85 °C

Contacts rating 250 VAC, 1.5 A

Mechanical life cycles +- 10 million operations

IP protection IP 54

Diaphragm Silicone

Case PA 6.6 and POM

These adjustable high sensitive differential pressure switches are used for monitoring overpressure, vacuum and differential pressure of air or other non-combustible, non-aggressive gases. The switching set-point can be adjusted by means of a calibrated knob. The switching differential P can be adjusted with a screw driver.

Possible applications are:

Air filters and fan monitoring

Overheating protection for electric batteries or electric heating elements

Controlling air- and fire-protection dampers

Monitoring air flows

Warranty

Two years from delivery date against defects in manufacturing. Any modifications or alterations to the product relieve the manufacturer of all responsibility. The manufacturer bears no responsibility for any misprints or mistakes in this data, and modifications or improvements to the product can be made at any time after date of publication.

Transport and stock keeping

Avoid shocks. Stock In original packing. Avoid extreme conditions

Maintenance

In normal conditions the controllers are maintenance-free. If soiled clean with dry or damp cloth. In case of heavy pollution clean with a non-aggressive product. In these circumstances the controller should be disconnected from the mains. Pay attention that no fluids enter the controller. Only reconnect the controller to the mains when it is completely dry.



General danger

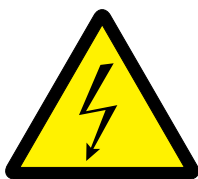

Electrical hazard

All works may only be carried out by skilled personnel following the local regulations, reference to the installation guide and AFTER the controller is completely separated from the mains.

SDXP54 – Pressure Sensor Controller

for Demand Proportional Drives



Features

- Supply: 15-24 VAC ±10 %/18-32 VDC ±10 %
- Modbus RTU on board RS485
- Auto-tune function
- Analogue output: 0-10 V/0-20 mA
- Digital output: PWM (open collector)
- Response time: 0.5, 1, 2 or 5 seconds
- Operating temperature: 10-60 °C (temperature compensated)
- Offset calibration procedure
- Selection of differential pressure or air volume mode/readout via Modbus
- Modbus registers reset function (Factory pre-set values)
- Aluminium pressure connection nozzles
- Usage in clean air and non-aggressive, non-combustible gases
- Long-term stability and accuracy
- Selectable Response time
- IP54 (according to EN 60529)
- Downloadable software and SDPUSB compatible

Description

The SDXP54 is a multi-range differential pressure transmitter with an analogue/digital output and Modbus RTU communication. This calibrated pressure transmitter has eight switchable measuring ranges and is equipped with a state-of-the-art monolithic silicon pressure sensor designed for a wide range of applications.

The piezo-resistive transducer is temperature and pressure compensated and has a high degree of reliability and accuracy. The transmitter has a pushbutton to activate manual zero point calibration and an adjustable offset. Typical applications are medical technology, ventilation and air conditioning ducts, clean rooms and filter monitoring. The sensor can measure air or other non-aggressive, non-combustible gases.

Ideal for variable air volume constant pressure (VAV) and constant air volume (CAV) systems.

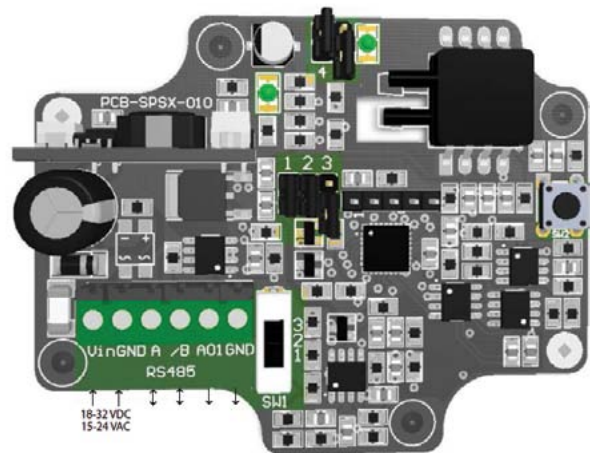

Range

Model	Description	Part
SDXP54-2000	Pressure sensor controller 0-2000Pa with Modbus RTU	EAO02105

Wiring Diagram

Vin - 15-24 VAC ±10 %/18-32 VDC ±10 %

GND - Ground

A - RS485 signal A

/B - RS485 signal /B

AO1 - Analogue (0-10 VDC/0-20 mA) or digital output (PWM)

GND - Ground

LED green – Normal

Power on red: calibration done and Modbus parameters reset

Switch analog output mode selection



SW1	1: 0-10 VDC
	2: 0-20 mA
	3: PWM (open collector)

Switch calibration



SW2	calibration switch zero point and factory preset of Modbus registers
-----	--

Jumper response time



4 5	Time
00	0,5 sec
08	1 sec (default)
88	2 sec
88	5 sec

Jumper setting range



1 2 3	Range
000	0 - 100 Pa
888	0 - 250 Pa
888	0 - 500 Pa
888	0 - 750 Pa
888	0 - 1.000 Pa (default)
888	0 - 2.000 Pa
888	-50 - +50 Pa
888	-100 - +100 Pa

Input Registers (read)

	Data Type	Description	Data	Values
1	Differential pressure	signed int.	Measured differential pressure	-100-2.000 1.000 = 1.000 Pa
2	Output Value	unsigned int.	Value of output 0-100%	0-1.000 100 = 10.0%
3	Max pressure limit flag	unsigned int.	Flag indicates pressure is over or below max. limit	0=below limit 1=over limit 2=value written in Holding register 14 is out of range -100-2000 Pa
4	Min pressure limit flag	unsigned int.	Flag indicates pressure is over or below min. limit	0= over limit 1=below limit 2=value written in Holding register 14 is out of range -100-2000 Pa
5	Volume flow rate	unsigned int.	Air volume flow rate is m ³ /h	0-44.000 1.000=1.000 m ³ /h
6		unsigned int.	Reserved, returns 0	
7	Differential pressure range	unsigned int.	Flag indicates current range of SPS-2KD	0=0-100 Pa 1=0-250 Pa 2=0-500 Pa 3=0-750 Pa 4=0-1.000 Pa 5=0-2.000 Pa 6=50-50 Pa 7=100-100 Pa

Constant Pressure with DP1S

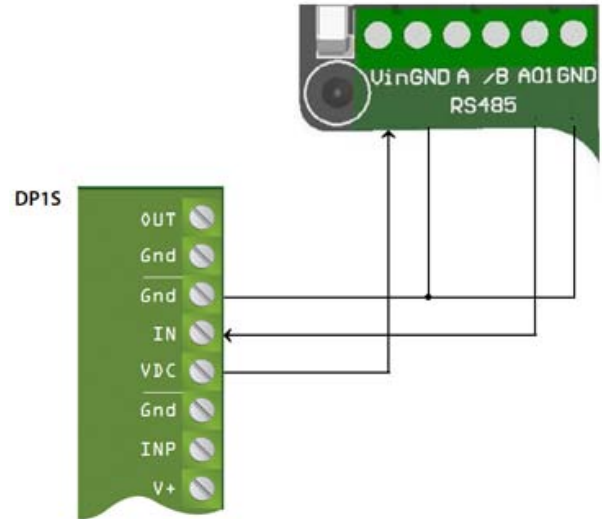

Holding Registers (read/write)

	Data Type	Description	Data	Values
1	Address	unsigned int.	Device address	1-247 (default: 1)
2	RS485 baud rate	unsigned int.	Modbus communication baud rate	1-9.600 2=19.200 (default) 3=38.400
3	RS485 parity mode	unsigned int.	Parity check mode	0=8N1 1=8E1 2=801 (default)
4	Device type	unsigned int.	Device type: read-only	SPS=8
5	HW Version	unsigned int.	Hardware version of the device, read-only	XXX 100 = HW version .00
6	SW Version	unsigned int.	Software version of the device, read-only	XXX 5000 = SW version 5.00
7			Reserved, returns 0	
8			Reserved, returns 0	
9			Reserved, returns 0	
10			Reserved, returns 0	
11	Mode	unsigned int.	Operating mode of SPS-2KD	1 = standalone 2 = Modbus mode (default)
12	Range	unsigned int.	SPS-2KD Range Selection	0=0-100 Pa 1=0-250 Pa 2=0-500 Pa 3=0-750 Pa 4=0-1.000 Pa 5=0-2.000 Pa 6=50-50 Pa 7=100-100 Pa
13	Response Time	unsigned int.	SPS-2KD Response Time Selection	0=0.5 s 1=1 s 2=2 s 3=3 s
14	Max Pressure Limit	signed int.	SPS-2KD Maximum Pressure Limit	-100 - 2.000 (default: 1.000) 1.000=1.000 Pa
15	Min Pressure Limit	signed int.	SPS-2KD Minimum Pressure Limit	-100-2000 (default:0) 1.000=1.000 Pa
16	Power-up Timer	unsigned int.	Power up timer before measure the lower limit	0-1.000 (default: 60) 100=100 s
17	K factor selection register	unsigned int.	K factor according to the motor type	0 = differential pressure management
18			Reserved, returns 0	
19			Reserved, returns 0	
20			Reserved, returns 0	

PWM (open collector) connection example

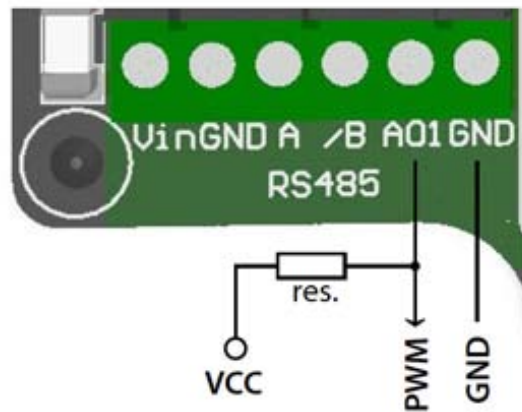

Connection of multiple SPS to BMS system in a network

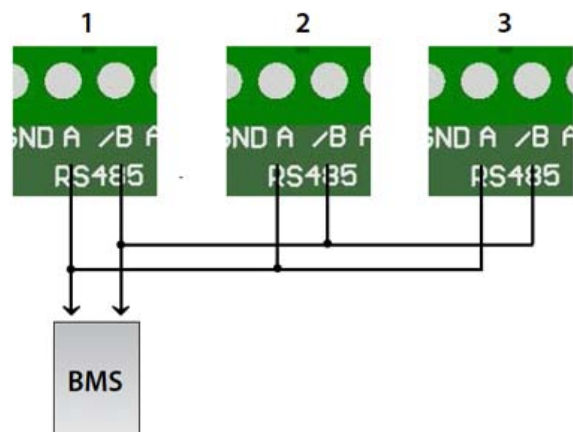

Reset Modbus registers

- Press button SW2 for four seconds until the red LED on the printed circuit board blinks twice
- Keep pressing until the red LED blinks three times, the Modbus registers are restored to their default (factory preset) values

Dimensions & Weights

fig. 1

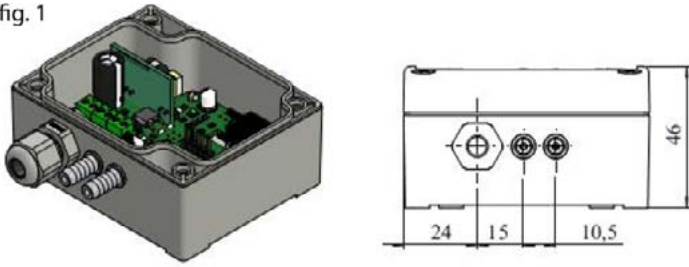
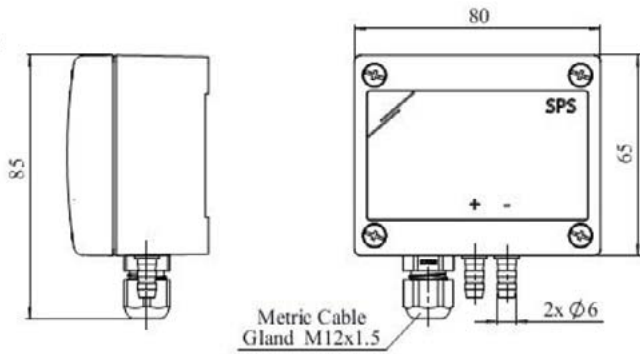

fig. 2



Model	Net weight (g)	Gross weight (g)
SDXP54	120	150

Mounting Instructions

Warranty

Two years from delivery date against defects in manufacturing. Any modifications or alterations to the product relieve the manufacturer of all responsibility. The manufacturer bears no responsibility for any misprints or mistakes in this data, and modifications or improvements to the product can be made at any time after date of publication.

Transport and stock keeping

Avoid shocks. Stock In original packing. Avoid extreme conditions

Maintenance

In normal conditions the controllers are maintenance-free. If soiled clean with dry or damp cloth. In case of heavy pollution clean with a non-aggressive product. In these circumstances the controller should be disconnected from the mains. Pay attention that no fluids enter the controller. Only reconnect the controller to the mains when it is completely dry.



General danger

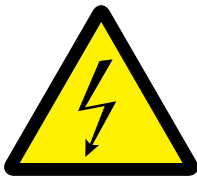

Electrical hazard

All works may only be carried out by skilled personnel following the local regulations, reference to the installation guide and AFTER the controller is completely separated from the mains.

SDPT54 – Room Temperature Sensor Controller

for Demand Proportional Drives



Features

- Built-in PT1000 temperature sensor
- IP54 ingress protection, ABS colour RAL7035
- Digital readout and step indication with LED's
- 5 user definable setpoints
- Modbus RTU (RS485) & set up software
- 15-24 VAC $\pm 10\%$ / 12-32 VDC $\pm 10\%$
- 1 analogue input (0-10 VDC/0-20 mA/PWM) *
- 1 analogue output (0-10 VDC/0-20 mA) or 1 digital output (PWM, open collector)
- Temperature range: -30 to 70 °C *
- Power consumption 15-24 VAC supply: max. 70 mA (no load on AO1) or 12-32 VDC supply: max. 85 mA (no load on AO1)
- Operating temperature: -10 to 50 °C

Description

The SDPT54 multifunctional controller series provides a temperature and/or an analogue input (0-10 VDC/0-20 mA/PWM) and a user-defined analogue output (0-10 VDC/0-20 mA/PWM) in five steps.

IP 54 rating makes this sensor ideal for use in small industrial or heavy commercial applications.

This controller is equipped with digital readout and step-indication with LED's enabling simple touch pad setup.

Combined with freely downloadable set up software and the SDPUSB connector; advanced programmable inputs and outputs make these controllers suitable for use in most HVAC applications.

Range

Model	Description	Part
SDXT54	Room Temperature Sensor Controller	EAO02106

Wiring Diagram

+ V - power supply: 15-24 VAC $\pm 10\%$ / 12-32 VDC $\pm 10\%$

GND - ground

Ai1 - analogue (0-10 VDC/0-20 mA) or digital input

GND - ground

T1 - connection for temperature sensor

A / B - Modbus RTU (RS485) connection signals

GND - ground

+5V - output 5 VDC/max 20 mA

GND - ground

AO1 - analogue (0-10 VDC/0-20 mA) or digital output (PWM)

GND - ground

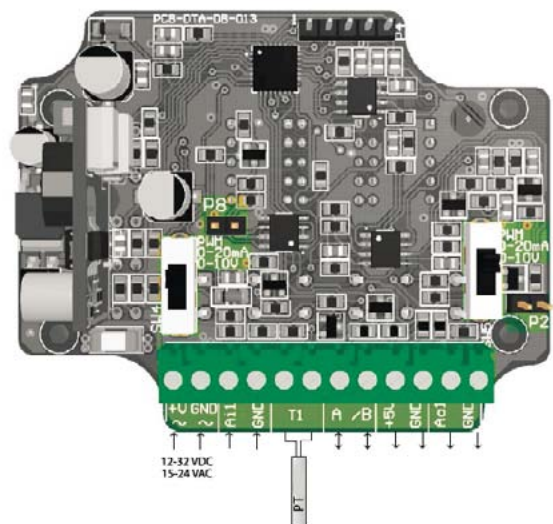

Switch analog input mode selection



SW4 analog input mode selection: 0-10 VDC/0-20 mA/PWM

Switch analog input mode selection



SW5 analog input mode selection: 0-10 VDC/0-20 mA/PWM

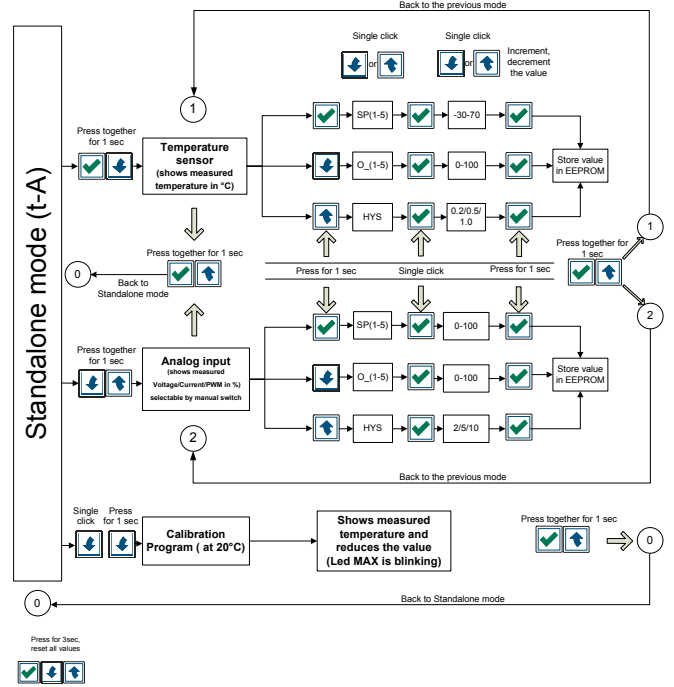
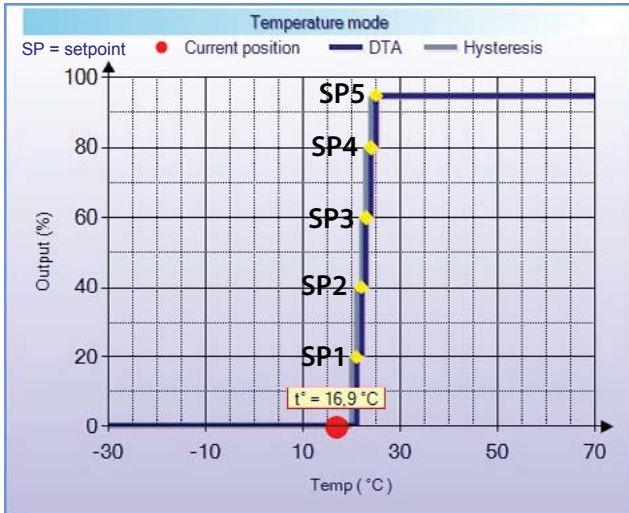

Jumper Network Bus Termination Resistor



P8	Resistor
	connected
	disconnected

Jumper PWM



P2	Resistor
	connected
	disconnected

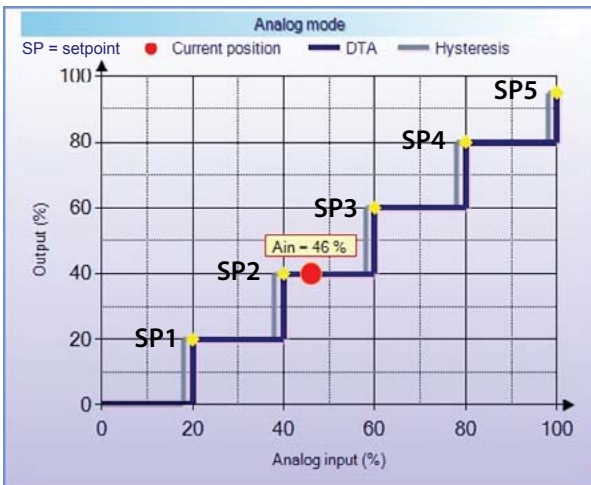

Holding Registers (read/write)

	Data Type	Description	Data	Values
1	Measured temperature	signed int.	Actual temperature input	-300-700 -300-30°C
2	Input Signal	unsigned int.	Actual analog input	0-1.000 700-70°C
3	Output value	unsigned int.	Actual analog output	0-1.000 100=10,00 VDC/2,00 mA/10% PWM
4	SP1	signed int.	Temperature/analog setpoint 1	-300-1.000
5	SP2	signed int.	Temperature/analog setpoint 2	-300=-30°C -700=70°C
6	SP3	signed int.	Temperature/analog setpoint 3	-300-1.000 0=0 VDC 1.000=10,00 VDC
7	SP4	signed int.	Temperature/analog setpoint 4	-300-1.000 0=0 VDC 1.000 = 20,00 mA
8	SP5	signed int.	Temperature/analog setpoint 5	-300-1.000 0=0% PWM 1.000 = 100% PWM
9	Output 1	unsigned int.	Output 1	0-1.000
10	Output 2	unsigned int.	Output 2	0-1.000 100=1,00VDC/2,00 mA/10% PWM
11	Output 3	unsigned int.	Output 3	0-1.000 1.000=10,00VDC/20,00 mA/10% PWM
12	Output 4	unsigned int.	Output 4	0-1.000
13	Output 5	unsigned int.	Output 5	0-1.000
14			Reserved, returns 0	
15			Reserved, returns 0	
16			Reserved, returns 0	
17			Reserved, returns 0	
18			Reserved, returns 0	
19			Reserved, returns 0	

Input Registers (read)

	Data Type	Description	Data	Values
1	Device address	Device address	1-247 (default:1)	
2	RS485 baud rate	Modbus communication baud rate	1-9.600 2=19.200 (default) 3=38.400	
3	RS485 parity mode	Parity check mode	0=8N1 1=8E1 (default) 2=8O1	
4	Device type	Device type, read-only	20	20=DTA-G
5	HW Version	Hardware version of the device, read-only	XXX	300 = HW version 3.00
6	SW Version	Software version of the device, read-only	XXX	130 = SW version 1.30
7		Reserved, returns 0		
8		Reserved, returns 0		
9	Input mode	Depends on chosen input	0-2 (default:0)	0-main screen 1-temperature input 2-analog input
10	Hysteresis	Input hysteresis	0-2 (default:0)	0=2%/0.2°C 1=5%/0.5°C 2=10%/1°C
11	SP1	Temperature setpoint 1	-300-700 (default:210)	
12	SP2	Temperature setpoint 2	-300-700 (default:220)	-300=30°C
13	SP3	Temperature setpoint 3	-300-700 (default:230)	700=70°C
14	SP4	Temperature setpoint 4	-300-700 (default:240)	
15	SP5	Temperature setpoint 5	-300-700 (default:250)	
16	Output 1	Output 1	0-1.000 (default:200)	
17	Output 2	Output 2	0-1.000 (default:400)	100=1,00 VDC/2,00 mA/10% PWM
18	Output 3	Output 3	0-1.000 (default:600)	1.000=10,00 VDC/20,00 mA/10% PWM
19	Output 4	Output 4	0-1.000 (default:800)	
20	Output 5	Output 5	0-1.000 (default:1.000)	
21	SP1	Analog setpoint 1	0-1.000 (default:200)	
22	SP2	Analog setpoint 2	0-1.000 (default:400)	
23	SP3	Analog setpoint 3	0-1.000 (default:600)	100=1,00 VDC/2,00 mA/10% PWM
24	SP4	Analog setpoint 4	0-1.000 (default:800)	1.000=10,00 VDC/20,00 mA/10% PWM
25	SP5	Analog setpoint 5	0-1.000 (default:1.000)	
26	Output 1	Output 1	0-1.000 (default:200)	
27	Output 2	Output 2	0-1.000 (default:400)	
28	Output 3	Output 3	0-1.000 (default:600)	
29	Output 4	Output 4	0-1.000 (default:800)	
30	Output 5	Output 5	0-1.000 (default:1.000)	

Drawings and Dimensions

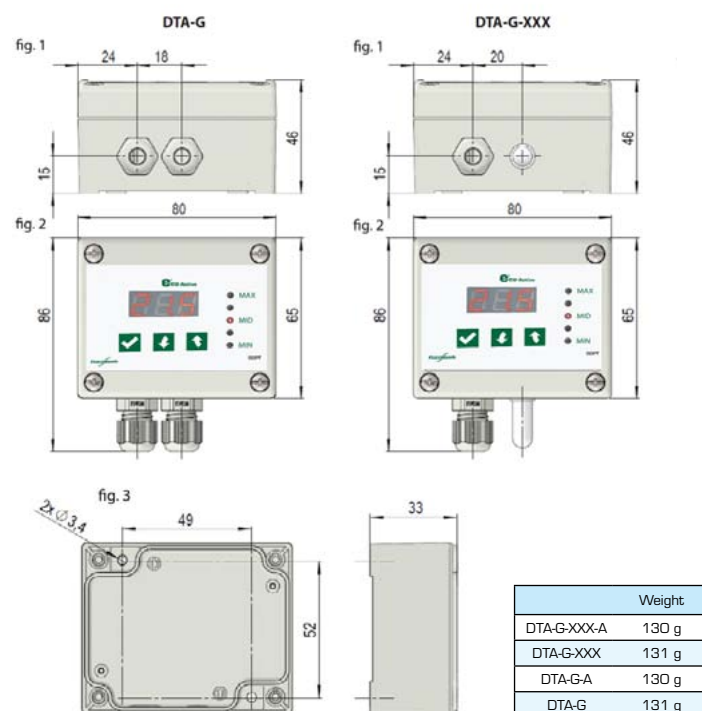

Mounting Instructions

Technical data
 Supply voltage: 15-24 VAC ±10 %/12-32 VDC ±10 %
 Operating temperature range: -10 to 50 °C
 Enclosure: plastic ABS, RAL7035
 Ingress Protection: IP5430

Wiring (see previous page diagram)

Mounting

The device is to be mounted in a room on a smooth surface, preferably at a minimum height of 1.50 m above the floor.

Transport and stock keeping

Avoid shocks. Stock in original packing. Avoid extreme conditions.

Warranty

Two years from delivery date against defects in manufacturing. Any modifications or alterations to the product relieve the manufacturer of all responsibility. The manufacturer bears no responsibility for any misprints or mistakes in this data, and modifications or improvements to the product can be made at any time after date of publication.

Maintenance

In normal conditions the controllers are maintenance-free. If soiled clean with dry or damp cloth. In case of heavy pollution clean with a non-aggressive product. In these circumstances the controller should be disconnected from the mains. Pay attention that no fluids enter the controller. Only reconnect the controller to the mains when it is completely dry.

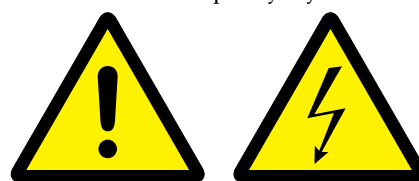

General danger

Electrical hazard

All works may only be carried out by skilled personnel following the local regulations, reference to the installation guide and AFTER the controller is completely separated from the mains.

SDPUSB - USB to Modbus RTU RS485 Connector



Features

- Easy plug & play installation.
- Downloadable software
- LED indication for receiving and transmitting signals
- Compatible with USB 1.1 and 2.0
- Installs as a standard Windows COM port
- USB port powered (Type A connector)
- Modbus RTU RS485 A, /B and GND connections

Description

The SDPUSB is a self-powered USB to Modbus RTU (RS485) module. The Modbus RTU serial information is automatically converted to serial information on a USB virtual COM port for both transmitted and received communication.

Range

Model	Description	Part
SDPUSB	USB to Modbus RTU 485 Connector	EAO02120

Drawing and Dimensions

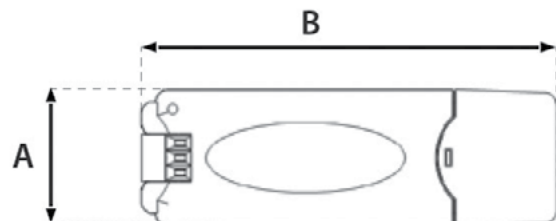

	A	B	C	weight
SDPUSB	23	71	8,7	12g

Wiring Diagram

A - RS485 signal A
 /B - RS485 signal /B
 GND - ground
 Parity - none, even and odd
 Data bits - 7 & 8
 Flow control - none

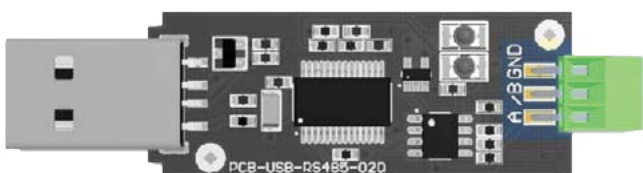

Mounting Instructions

Connect only to USB ports (Type A connector) and RS485 A /B GND terminals.

COM port number can be changed to any available number, to support HyperTerminal or any other serial communications software application running in Windows Microsoft Windows® WHQL-certified, Mac OS X, Linux and Windows CE device drivers.

FIFO: 128 byte transmit buffer, 256 byte receive buffer
ESD protection for RS485 in & outputs : ± 15 kV Human Body Model (HBM) and ± 15 kV
EN61000-4-2 Air Gap Discharge, ± 8 kV EN61000-4-2 Contact Discharge
Parity: none, even, odd
Data bits: 7, 8
Flow control: none

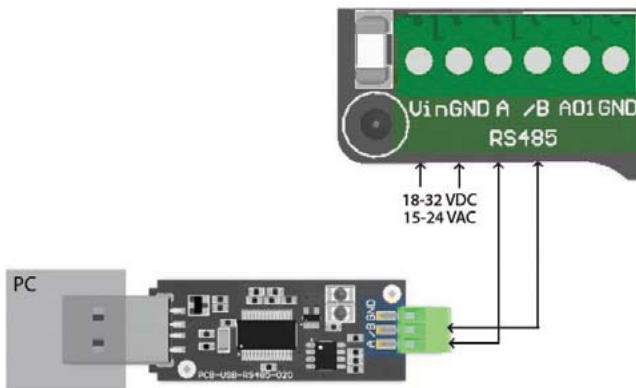

Technical data

Operating temperature: -10 $+50^{\circ}\text{C}$

Wiring (see diagram on previous page)

The cable connecting the device control should not exceed 4 m.

Transport and stock keeping

Avoid shocks and extreme conditions, stock in original packing.

Warranty

Two years from delivery date against defects in manufacturing. Any modifications or alterations to the product relieve the manufacturer of all responsibility. The manufacturer bears no responsibility for any misprints or mistakes in this data, and modifications or improvements to the product can be made at any time after date of publication.

Maintenance

In normal conditions the controllers are maintenance-free. If soiled clean with dry or damp cloth. In case of heavy pollution clean with a non-aggressive product. In these circumstances the controller should be disconnected from the mains. Pay attention that no fluids enter the controller. Only reconnect the controller to the mains when it is completely dry.



General danger

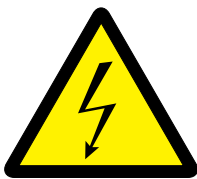

Electrical hazard

All works may only be carried out by skilled personnel following the local regulations, reference to the installation guide and AFTER the controller is completely separated from the mains

Potentiometers & Power Supply

SDPV-10 Room Potentiometer

for Demand Proportional Drives



Features

- Minimum (V_{min}) and maximum (V_{max}) output setting by internal trimmer
- IP rating flush mounting: IP44, surface mounting: IP54
- Enclosure external: plastic ASA, RAL 9010 white-ivory
- Enclosure internal: polyamide according to IEC 60335
- Operating temperature: 0...40 °C
- Supply (V_{in}) 3-15 VDC
- V_{min} 10-70 % V_{in}
- V_{max} 30-100 % V_{in}
- Load $\geq 2 \text{ k}\Omega$
- Consumption $\leq 10 \text{ mA}$ incl. load
- Off-position

Description

These potentiometers are designed to control fans equipped with an EC motor or in any application where a DC control signal of 0-10VDC is required; such as demand proportional drives. It is mounted in a splash water proof design enclosure and can be used for inset as well as for surface mounting. There

The SDPV-10 is supplied with customer adjustable min and max settings pre-set from the factory for V_{min} 20% and V_{max} 100%.

A supply voltage between 3 and 15 VDC is required to provide an infinitely variable output signal between two internally selectable positions: V_{min} and V_{max} . The load may not be lower than 2 kOhm ($R_L \geq 2 \text{ k}\Omega$).

Range

Model	Description	Part
SDPV-10	Potentiometer Out: 10VDC	EAD02107

Wiring Diagram

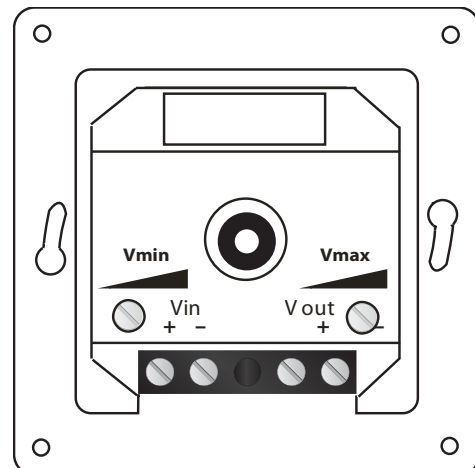
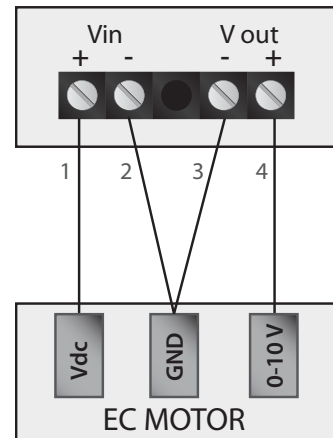

Drawings and Dimensions

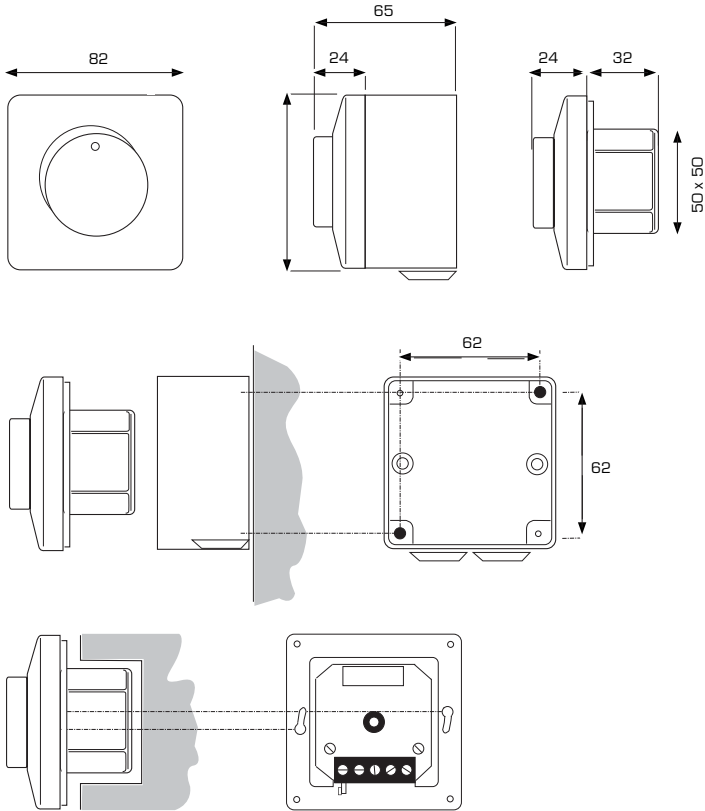

Warranty

Two years from delivery date against defects in manufacturing. Any modifications or alterations to the product relieve the manufacturer of all responsibility. The manufacturer bears no responsibility for any misprints or mistakes in this data, and modifications or improvements to the product can be made at any time after date of publication.

Maintenance

In normal conditions the controllers are maintenance-free. If soiled clean with dry or damp cloth. In case of heavy pollution clean with a non-aggressive product. In these circumstances the controller should be disconnected from the mains. Pay attention that no fluids enter the controller. Only reconnect the controller to the mains when it is completely dry.



General danger

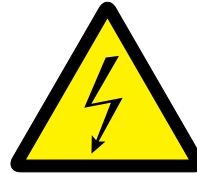

Electrical hazard

All works may only be carried out by skilled personnel following the local regulations, reference to the installation guide and AFTER the controller is completely separated from the mains.

Mounting Instructions

Technical data

Supply (Vin) 3-15 VDC

Vmin 10-70 % Vin Vmax 30-100 % Vin

Load $\geq 2 \text{ k}\Omega$

Consumption $\leq 10 \text{ mA}$ incl. load

Off-position

Enclosure external: plastic ASA, RAL 9010 white-ivory

Enclosure internal: polyamide according to IEC 60335

Operating temperature: 0...40 °C

This potentiometer is developed to control fans equipped with an EC motor or other demand proportional drive requiring 0-10VDC input. It is mounted in a splash water proof housing and can be used for inset as well as for surface mounting. The potentiometer requires a supply between 3 VDC and 15 VDC, and it provides a stepless output signal between voltage Vmin and voltage Vmax. Vmin and Vmax are internally selectable. Position 0 is the off-position. The load cannot be lower than 2 k Ω (RL $\geq 2 \text{ k}\Omega$).

Inset mounting (IP 44)

Connect according to the diagram. Mount the inner case to the wall with the connections pointing down. Mount cover with nut to the wall. Push knob in place at off position.

Surface mounting (IP 54)

Mount the case to the wall together with included grommets. Connect according to the diagram. Mount inner case in surface mounting case with included screws. Mount cover with nut to surface mounting case. Push knob in place at off position. When needed a 5 mm hole for condensation water is to be drilled at the bottom of the surface mounting case.

Wiring (see diagram on previous page)

The cable connecting the device control should not exceed 4 m. For a cable length between 4 and 12 m we recommend using a shielded cable. For cable longer than 12 m use the SDPV-230 device.

Transport and stock keeping

Avoid shocks and extreme conditions, stock in original packing.

Potentiometers & Power Supply

SDPV-230 - Room Potentiometer

for Demand Proportional Drives



Features

- Voltage supply: 230 VAC, 50/60 Hz
- Selectable output: 0-10 V, 0-20 mA & PWM
- Load: 0-10 V and PWM > 2 kΩ / 0-20 mA < 500 Ω
- Minimum (Vmin) and maximum (Vmax) output setting by internal trimmer
- IP rating flush mounting: IP44, surface mounting: IP54
- Enclosure external: plastic ASA, RAL 9010 white-ivory
- Enclosure internal: polyamide according to IEC 60335
- Operating temperature: 0...40 °C

Description

This potentiometer is developed to control fans equipped with an EC motor or demand proportional drives without a 10VDC output. It is mounted in a splash water proof housing and can be used for inset as well as for surface mounting.

The potentiometer needs a supply of 230 VAC, and gives a stepless output signal of 0-10 VDC or 0-20 mA and PWM between voltage Vmin and voltage Vmax. Position 0 is the off-position. The load cannot be lower than 2 kΩ (RL ≥ 2 kΩ) in 0-10 V output mode or higher than 500 Ω if 0-20 mA

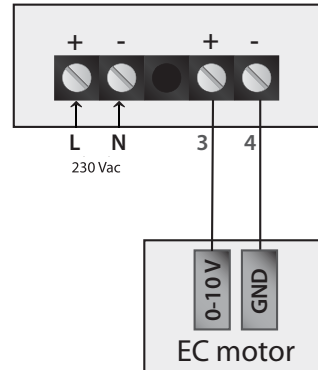

Range

Model	Description	Part
0	Potentiometer In:230VAC Out:10VDC	EAO02108

Wiring Diagram

L N - power supply 230 VAC

Vout - output 0-10 VDC / 0-20 mA / PWM

Vmin - adjustment trimmer min speed

Vmax - adjustment trimmer max speed

SW switch analogue output selection: 0-10 VDC / 2: 0-20 mA / 3: PWM

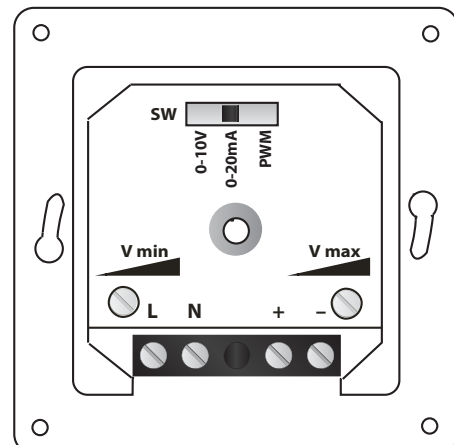

Drawings and Dimensions

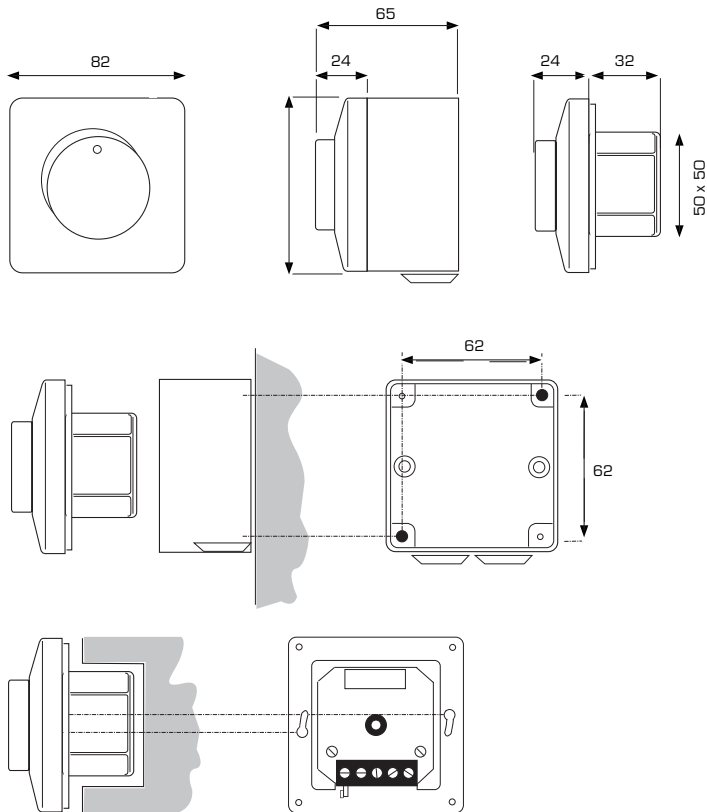

Two years from delivery date against defects in manufacturing. Any modifications or alterations to the product relieve the manufacturer of all responsibility. The manufacturer bears no responsibility for any misprints or mistakes in this data, and modifications or improvements to the product can be made at any time after date of publication.

Maintenance

In normal conditions the controllers are maintenance-free. If soiled clean with dry or damp cloth. In case of heavy pollution clean with a non-aggressive product. In these circumstances the controller should be disconnected from the mains. Pay attention that no fluids enter the controller. Only reconnect the controller to the mains when it is completely dry.



General danger

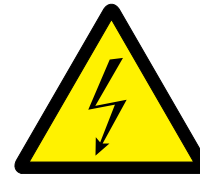

Electrical hazard

All works may only be carried out by skilled personnel following the local regulations, reference to the installation guide and AFTER the controller is completely separated from the mains

Mounting Instructions

Technical data

Mode 0-10 V 0-20 mA PWM

Output 0, 1-10 V 0, 2-20 mA 0, 10 - 100 % PWM

V_{min} 1 - 7 VDC 2-10 mA 10-70 % PWM

V_{max} 3 - 10 VDC V_{max}: 6-20 mA 30-100 % PWM

Enclosure external: plastic, ASA, RAL 9010 white-ivory

Enclosure internal: polyamide According to IEC 60335

Operating temperature: 0...40 °C

This potentiometer is developed to control fans equipped with an EC-motor. It is mounted in a splash water proof housing and can be used for inset as well as for surface mounting.

The potentiometer needs a supply of 230 VAC, and gives a stepless output signal of 0-10 VDC or 0-20 mA and PWM between voltage V_{min} and voltage V_{max}. Position 0 is the off-position. The load cannot be lower than 2 kΩ (RL ≥ 2 kΩ) in 0-10 V output mode or higher than 500 Ω if 0-20 mA output is selected.

Inset mounting (IP 44)

Break mains voltage. Connect according to diagram. Mount the inner case to the wall with the connections pointing down. Mount cover with nut to the wall. Push knob in place at off position.

Surface mounting (IP 54)

Break mains voltage. Mount surface mounting case to the wall together with included grommets. Connect according to diagram. Mount inner case in surface mounting case with included screws. Mount cover with nut to surface mounting case. Push knob in place at off position. When needed a 5 mm hole for condensation water is to be drilled at the bottom of the surface mounting case.

Wiring (see previous page)

Transport and stock keeping

Avoid shocks and extreme conditions, stock in original packing.

Warranty

SDXV – Power Supply

for Sensors & Switches 230VAC to 24VDC



Features

- Input voltage: 195-265 Vac at 50/60 Hz
- Short circuit protection
- Over current protection: 120-150 % of rated current
- Automatic recovery after fault condition is removed
- Voltage tolerance: $\pm 2\%$
- Load regulation: $\pm 2\%$
- Cooling type: free air convection
- DIN rail mounting
- Power consumption: without load < 1W
- Available output voltage: 24 VAC
- Internal noise filter
- IP30 protection
- Working temperature: 0...70 °C

Description

A low cost DIN rail mountable switching power supplies designed especially for use with sensors & controls. Converting 230VAC to 24VAC 4A for safety in control circuits.

The SDVX power supply (PSU) offers a reliable power source, is short circuit protected with high efficiency and low ripple and is suitable for use with sensors, electromechanical relays, contactors, solid state relays, timers, thermal regulators, PLC's, controllers, DC motors, solenoids, displays and other types of custom electronics.

Range

Model	Description	Part
SDXV	Power Supply 230VAC to 24VAC	EA002109

Wiring Diagram

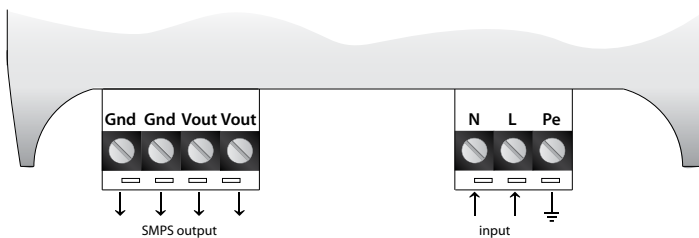

Dimensions

Amps	W (mm)	H (mm)	D (mm)	Net weight (g)	Gross weight (g)
SDXV	45	101	110	230	250

Mounting Instructions

Wiring (see diagram)

Transport and stock keeping

Avoid shocks and extreme conditions, stock in original packing.

Warranty

Two years from delivery date against defects in manufacturing. Any modifications or alterations to the product relieve the manufacturer of all responsibility. The manufacturer bears no responsibility for any misprints or mistakes in this data, and modifications or improvements to the product can be made at any time after date of publication.

Maintenance

In normal conditions the controllers are maintenance-free. If soiled clean with dry or damp cloth. In case of heavy pollution clean with a non-aggressive product. In these circumstances the power supply and attached equipment should be disconnected from the mains. Pay attention that no fluids enter the power supply. Only reconnect the controller to the mains when it is completely dry.



General danger

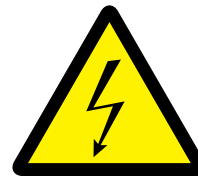

Electrical hazard

All works may only be carried out by skilled personnel following the local regulations, reference to the installation guide and AFTER the controller is completely separated from the mains.